

TEKTRONIX®

7633/R7633

**STORAGE
OSCILLOSCOPE**

OPERATORS

INSTRUCTION MANUAL

Tektronix, Inc.
P.O. Box 500
Beaverton, Oregon 97005

Serial Number

702-856

WARRANTY

Tektronix warrants that this product is free from defects in materials and workmanship. The warranty period is one (1) year from the date of shipment. Tektronix will, at its option, repair or replace the product if Tektronix determines it is defective within the warranty period and if it is returned, freight prepaid, to a service center designated by Tektronix.

Tektronix is not obligated to furnish service under this warranty

- a. to repair damage resulting from attempts by personnel other than Tektronix representatives to install, repair, or service the product;
- b. to repair damage resulting from improper use or from connecting the product to incompatible equipment;
- c. if personnel other than Tektronix representatives modify the hardware or software.

There is no implied warranty of fitness for a particular purpose. Tektronix is not liable for consequential damages.

Copyright © 1974, Tektronix, Inc. All rights reserved. Contents of this publication may not be reproduced in any form without the written permission of Tektronix, Inc.

Products of Tektronix, Inc. and its subsidiaries are covered by U.S. and foreign patents and/or pending patents.

TEKTRONIX, TEK, SCOPE-MOBILE, and  are registered trademarks of Tektronix, Inc.

Printed in U.S.A. Specification and price change privileges are reserved.

TABLE OF CONTENTS

	Page
LIST OF ILLUSTRATIONS	iii
LIST OF TABLES	iii
SECTION 1 OPERATING INSTRUCTIONS	1-1
PRELIMINARY OPERATION	1-1
AC POWER SOURCES	1-1
AC POWER CORD	1-1
OPERATING VOLTAGE	1-1
OPERATING TEMPERATURE	1-3
RACKMOUNTING	1-3
PLUG-IN UNITS	1-4
PLUG-IN INSTALLATION AND REMOVAL	1-4
CONTROLS AND CONNECTORS	1-5
FRONT PANEL CONTROLS AND CONNECTORS	1-6
REAR PANEL CONTROLS AND CONNECTORS	1-8
OPERATING CHECKOUT	1-10
GENERAL	1-10
SET-UP INFORMATION	1-10
DISPLAY FOCUS	1-11
TRACE ALIGNMENT	1-11
GRATICULE ILLUMINATION	1-11
VERTICAL DEFLECTION SYSTEM	1-11
TRIGGERING	1-12
HORIZONTAL DEFLECTION SYSTEM	1-13
STORAGE OPERATION	1-13
BEAMFINDER	1-16
Z-AXIS INPUT	1-16
GENERAL OPERATING INFORMATION	1-16
INTENSITY CONTROL	1-16
DISPLAY FOCUS	1-17
GRATICULE	1-17
LIGHT FILTER	1-18
BEAMFINDER	1-18
REDUCED SCAN MODE	1-18

TABLE OF CONTENTS (cont.)

	Page
READOUT MODES	1-19
DISPLAY PHOTOGRAPHY	1-19
STORAGE	1-20
CARE OF STORAGE SCREEN	1-21
VERTICAL MODE	1-22
TRIGGER SOURCE	1-23
X-Y OPERATION	1-24
INTENSITY MODULATION	1-24
RASTER DISPLAY	1-25
CALIBRATOR	1-25
SIGNALS OUT	1-26
APPLICATIONS	1-27
SECTION 2	SPECIFICATION
	INTRODUCTION
	STANDARD ACCESSORIES
	2-1
	2-1
	2-9
SECTION 3	RACKMOUNTING INSTRUCTIONS
	INTRODUCTION
	INSTALLATION INSTRUCTION
	RACK DIMENSIONS
	SLIDE OUT TRACKS
	MOUNTING PROCEDURE
	REMOVING OR INSTALLING THE INSTRUMENT
	SLIDE-OUT TRACK LUBRICATION
	3-1
	3-1
	3-1
	3-1
	3-2
	3-4
	3-5
	3-5
SECTION 4	OPTIONS
	4-1

LIST OF ILLUSTRATIONS

	Page
FRONTISPIECE	
Figure 1-1. Location of voltage-selector jumper.	1-2
Figure 1-2. Front panel controls and connectors.	1-5
Figure 1-3. Rear panel controls and connectors.	1-9
Figure 1-4. Definition of measurement lines on the graticule.	1-17
Figure 1-5. Location of Readout Mode switch.	1-19
Figure 1-6. Location of Calibrator jumper on Storage circuit board.	1-26
Figure 3-1. Slide out track assembly and mounting hardware.	3-1
Figure 3-2. Vertical mounting position of the left stationary section and the securing hole location. These dimensions also apply to the right front rail.	3-2
Figure 3-3. Details for mounting stationary sections.	3-3
Figure 3-4. Installing and removing the instrument.	3-4
Figure 3-5. Adjusting the slide out tracks for smooth sliding action.	3-5
Figure 3-6. Dimensional drawing.	3-6

LIST OF TABLES

TABLE 1-1. Power Cord Color Coding	1-1
TABLE 1-2. Regulating Range and Fuse Data	1-3
TABLE 2-1. ELECTRICAL	2-1
TABLE 2-2. ENVIRONMENTAL	2-8
TABLE 2-3. PHYSICAL	2-8
TABLE 2-4. 7633 SYSTEM SPECIFICATIONS	2-10

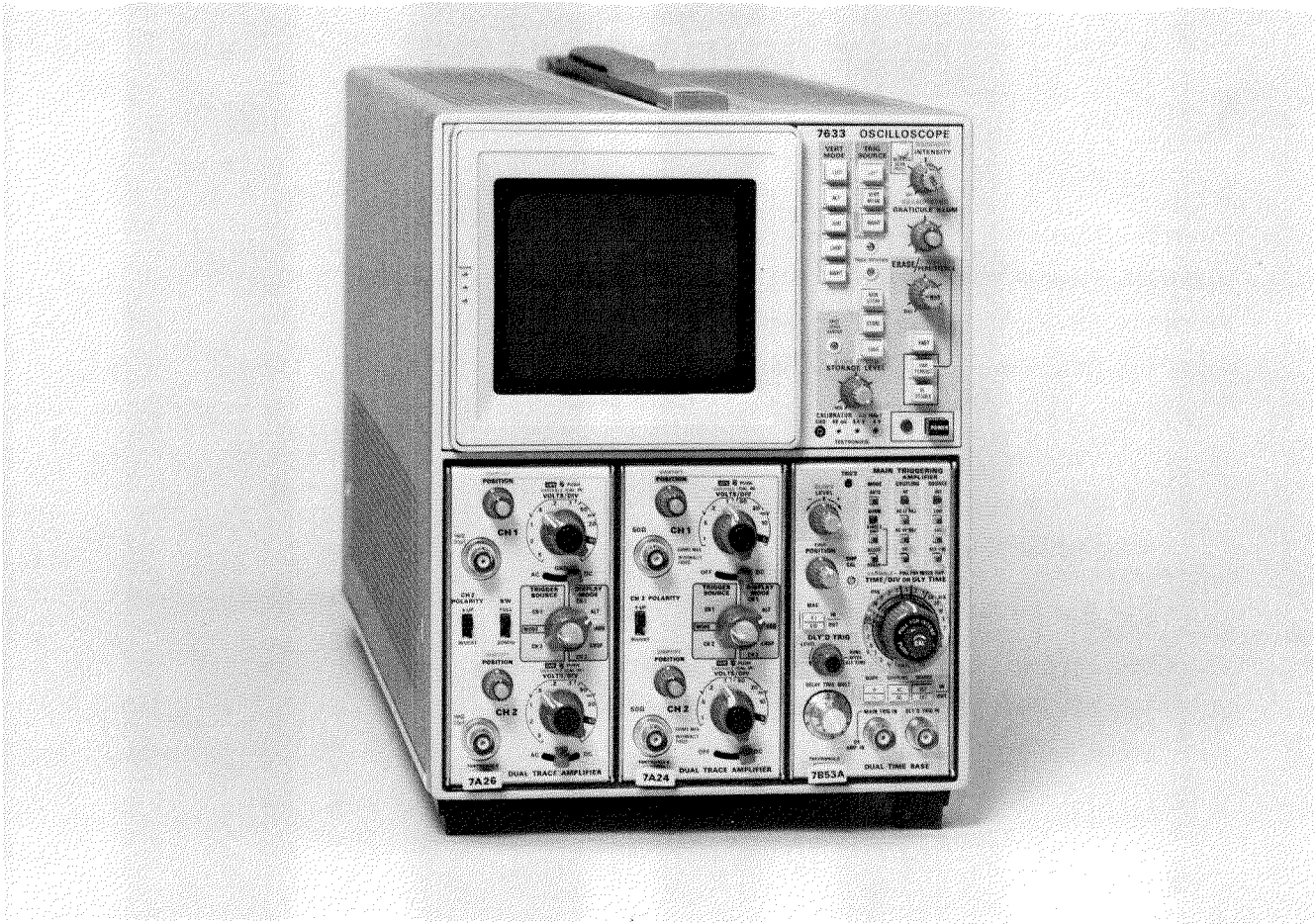

The Tektronix 7633/R7633 Storage Oscilloscope is a solid-state instrument especially designed for fast writing rate storage applications. The 7633 operates in three display modes—NON STORE, STORE, and SAVE, and four storage modes—BISTABLE, VAR PERSIST, FAST BISTABLE, and FAST VAR PERSIST. The display and storage functions can be operated in either a full scan or a Reduced Scan mode. In FAST VAR PERSIST, the Reduced Scan feature effectively increases the writing speed approximately seven times. The instrument accepts any Tektronix 7-Series plug-in units to form a highly flexible measurement system.

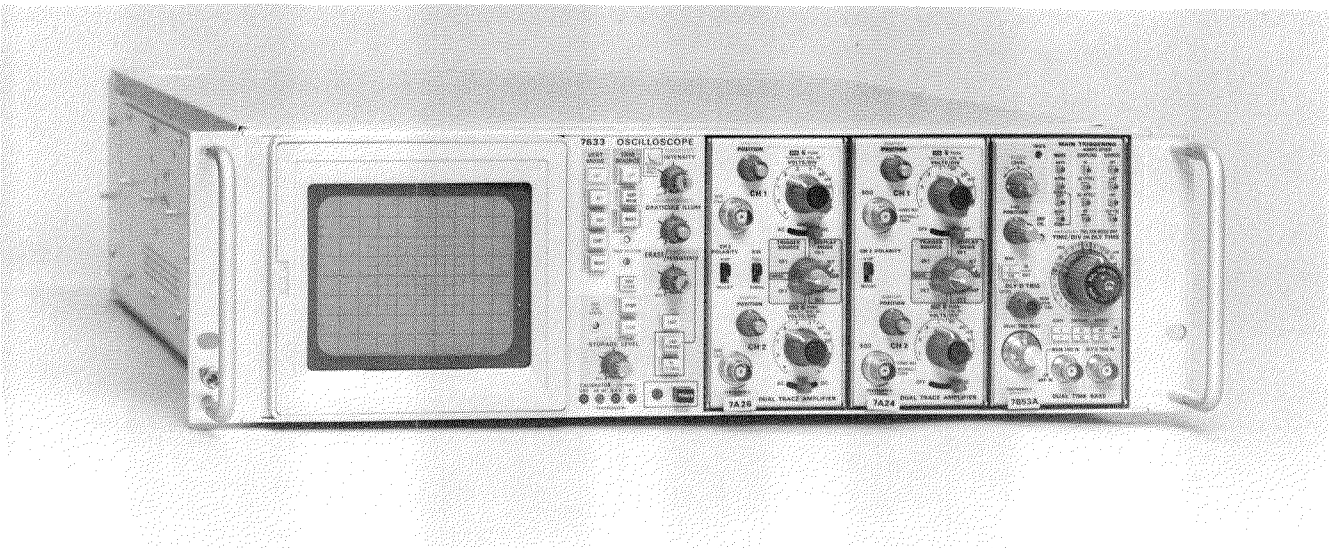

OPERATING INSTRUCTIONS

PRELIMINARY OPERATION

To effectively use the 7633/R7633 Storage Oscilloscope, the operation and capabilities of the instrument must be known. This section provides preliminary operating information, describes operation of controls and connectors, and provides an operating checkout procedure.

AC POWER SOURCES

This instrument is intended to be operated from a single-phase, earth-referenced power source having one current-carrying conductor (the Neutral Conductor) near earth potential. Operation from power sources where both current-carrying conductors are live with respect to earth (such as phase-to-phase on a three-wire system) is not recommended since only the Line Conductor has over-current (fuse) protection within the instrument.

AC POWER CORD

This instrument has a three-wire power cord with a three-terminal polarized plug for connection to the power source and safety-earth. The safety-earth terminal of the plug is directly connected to the instrument frame. For electric-shock protection, insert this plug only in a mating outlet with a safety-earth contact or otherwise connect the frame to a safety earth system. The color-coding of the cord conductors is in accordance with recognized standards as shown in Table 1-1.

TABLE 1-1

Power Cord Conductor Identification

Conductor	Color	Alternate Color
Ungrounded (line)	Brown	Black
Grounded (neutral)	Blue	White
Grounding (Earthing)	Green-Yellow	Green-Yellow

OPERATING VOLTAGE

The 7633/R7633 can be operated from either a 110-volt or a 220-volt nominal line-voltage source. In addition, three operating ranges can be selected within each nominal line voltage source. Use the following procedure to obtain correct instrument operation from the line voltage available:

1. Disconnect the instrument from the power source.
2. Remove the six screws securing the power unit (nine screws in the R7633; see Figure 1-1).
3. Slide the power unit out of the rear of the chassis.

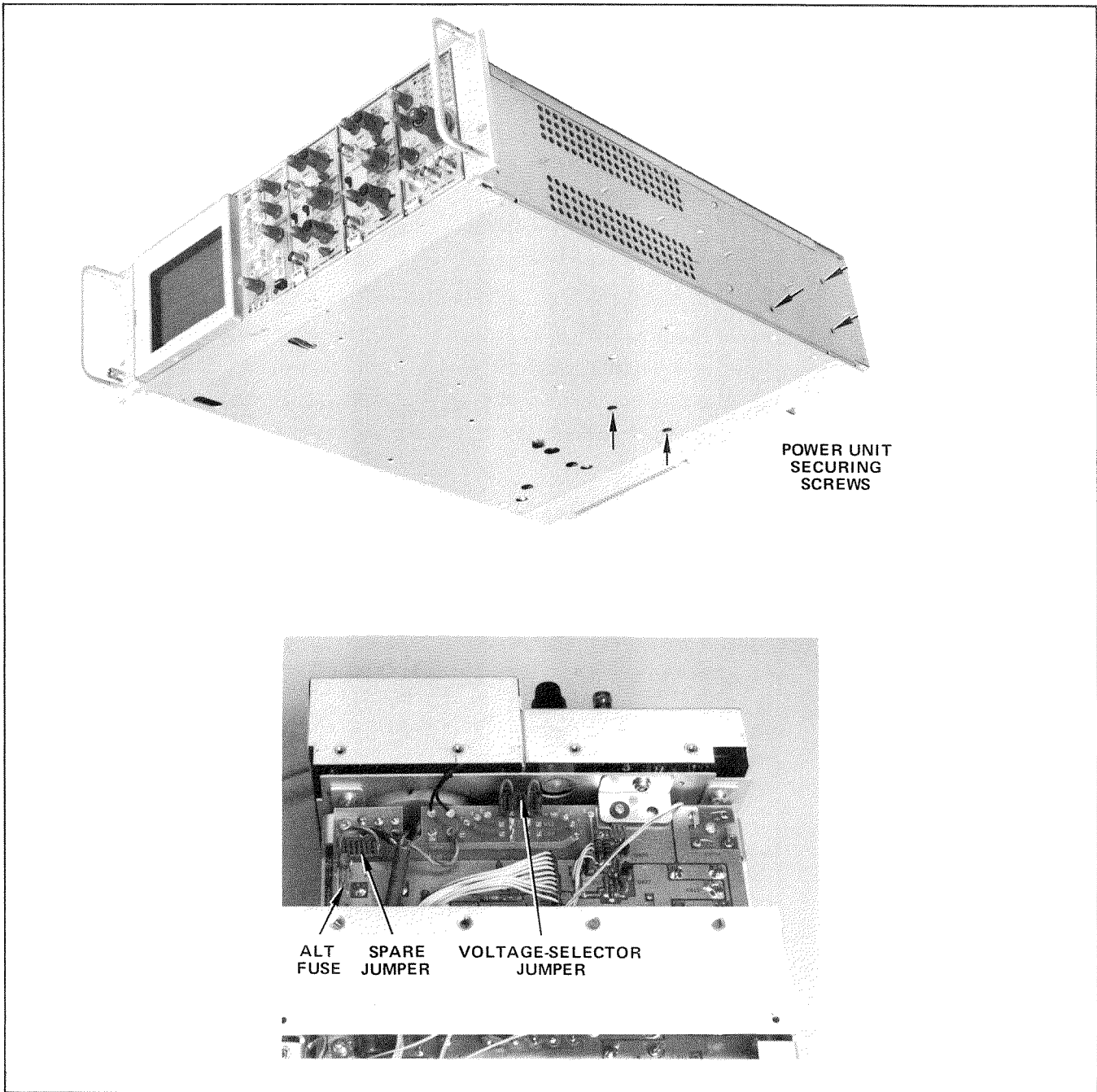

Figure 1-1. Location of voltage-selector jumper.

4. To convert from 110-volts to 220-volts nominal line voltage, or vice versa, remove the voltage-selector jumper and replace it with the spare jumper stored on the pins adjacent to the voltage selector area (see Figure 1-1). The jumpers are color coded to indicate the nominal voltage for which they are intended; brown for 110-volt nominal operation and red for 220-volt nominal operation. Change the fuse to provide protection for the selected nominal line voltage. Use the fuse located in the Alt Fuse holder on the Rectifier board (see Figure 1-1 for fuse location and Table 1-2 for fuse type). Also, change the line-cord plug to match the power-source receptacle or use a suitable adapter.

5. To convert the instrument from one regulating range to another, remove the voltage selector jumper and re-install it on the set of pins corresponding to the desired regulating range. The proper regulating range will center about the average line voltage to which the instrument is to be connected (see Table 1-2).

TABLE 1-2
Regulating Range and Fuse Data

Pins Selected	Regulating Range	
	110-volts (nominal)	220-volts (nominal)
LOW	90 to 110 volts	180 to 220 volts
MED	99 to 121 volts	198 to 242 volts
HI	108 to 132 volts	218 to 262 volts
Line Fuse	3.2 A slow-blow	1.6 A slow-blow

OPERATING TEMPERATURE

The 7633 can be operated where the ambient air temperature is between 0°C and +50°C. This instrument can be stored in ambient temperatures between -55°C and +75°C. After storage at temperatures beyond the operating limits, allow the chassis temperature to come within the operating limits before power is applied.

The 7633 is cooled by air drawn in through the top, side, and bottom panels and exhausted through the rear panel. Components that require most cooling are mounted externally on a heat radiator. Adequate clearance must be provided on all sides to allow heat to be dissipated from the instrument. Do not block or restrict the air flow through the holes in the cabinet or the heat radiator. Maintain the clearance provided by the feet on the bottom and allow about two inches clearance on the top, sides, and rear (more if possible).

The R7633 is cooled by air drawn in through the air filter on the rear panel and exhausted through ports on the right side of the instrument. Adequate clearance must be provided at these locations. Allow at least one and one-half inches clearance behind the air filter and at least one inch on the right side.

A thermal cutout interrupts power to the instrument if the internal temperature exceeds a safe operating level. Power is automatically restored when the temperature returns to a safe level. Operation in confined areas or close to a heat source may cause the thermal cutout to open.

RACKMOUNTING

Instructions and dimensional drawings for rackmounting the R7633 are located in Section 3.

PLUG-IN UNITS

The 7633 will accept up to three 7-series plug-in units. This plug-in feature permits a variety of display combinations and also allows selection of bandwidth, sensitivity, display mode, etc. to meet many measurement requirements. In addition, it allows expansion of the oscilloscope system to meet future measurement requirements. The overall capabilities of the resultant system are in large part determined by the characteristics of the plug-in selected. For complete information on plug-ins available for use with this instrument, see the current Tektronix, Inc., catalog.

PLUG-IN INSTALLATION AND REMOVAL

To install a plug-in unit into one of the plug-in compartments, align the slots in the top and bottom of the plug-in with the associated guide rails in the plug-in compartment. Push the plug-in unit firmly into the plug-in compartment until it locks into place. To remove a plug-in, pull the release latch on the plug-in unit to disengage it and pull the unit out of the plug-in compartment. Plug-in units can be removed or installed without turning off the instrument power.

It is not necessary that all of the plug-in compartments be filled to operate the instrument; the only plug-in units needed are those required for the measurement to be made. However, at environmental extremes, excess radiation may be radiated into or out of this instrument through the open plug-in compartments. Blank plug-in panels are available from Tektronix, Inc., to cover the unused compartment; order Part No. 016-0155-00.

When the 7633 is calibrated in accordance with the calibration procedure given in the Service manual, the vertical and horizontal gains are standardized. This allows calibrated plug-in units to be changed from one plug-in compartment to another without recalibration. However, the basic calibration of the individual plug-in units should be checked when they are installed in this system to verify their measurement accuracy. See the plug-in unit instruction manual for verification procedure.

Special purpose plug-in units may have specific restrictions regarding the plug-in compartments in which they can be installed. This information will be given in the instruction manual for these plug-in units.

CONTROLS AND CONNECTORS

The major controls for operation of the 7633 are located on the front panel of the instrument. These are illustrated in Figure 1-2. Figure 1-3 shows the location of rear panel controls and connectors. The following is a brief description of the controls and connectors shown in Figures 1-2 and 1-3. More detailed operating information is given under General Operating Information.

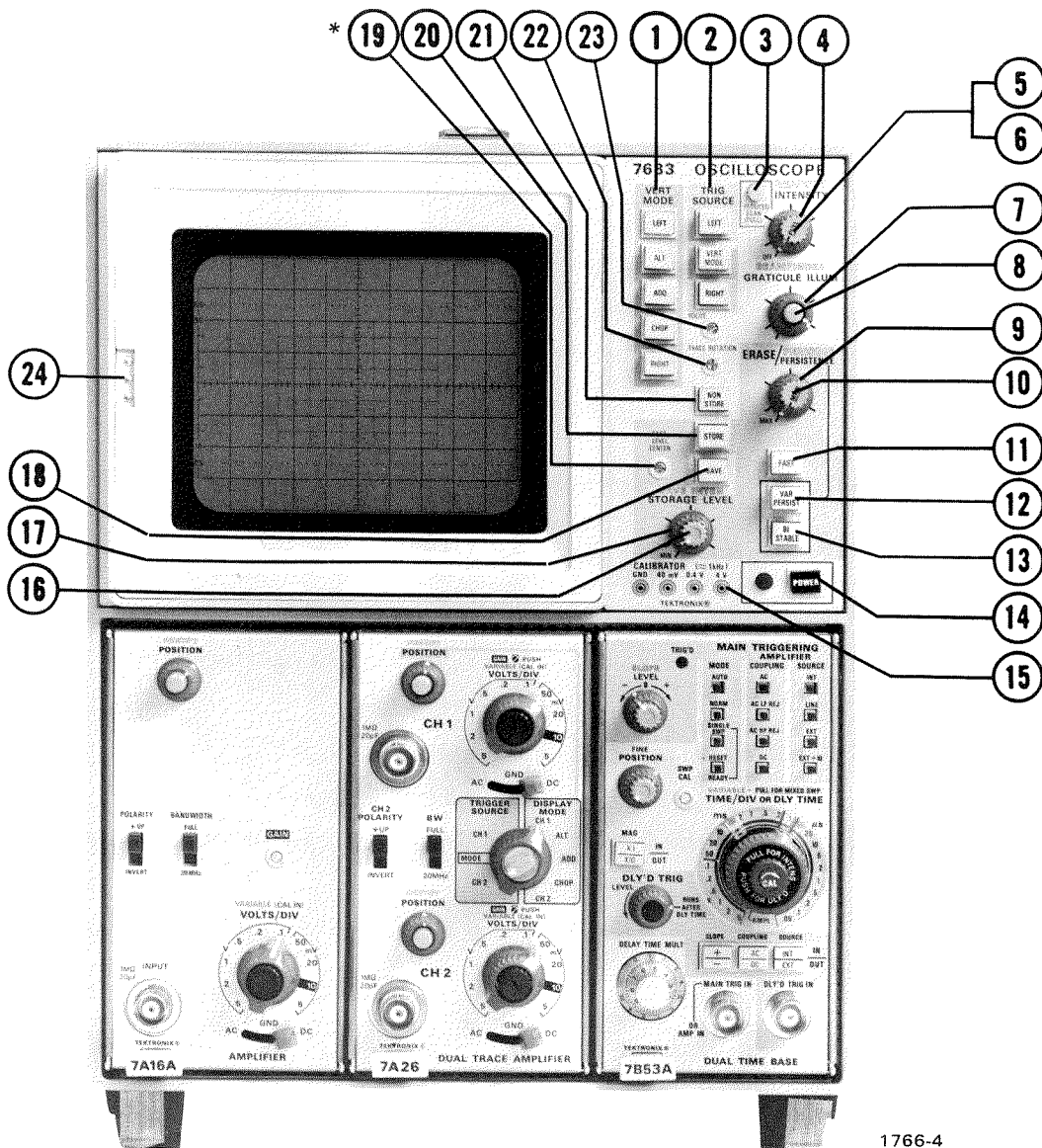

1766-4

Figure 1-2. Front panel controls and connectors.

FRONT PANEL CONTROLS AND CONNECTORS

The following descriptions are referenced to Figure 1-2.

- ① **VERT MODE:** Selects vertical mode operation.
 - LEFT:** Selects signals from the left vertical amplifier compartment for display.
 - ALT:** Selects signals from both vertical compartments for display on alternate sweeps (dual trace).
 - ADD:** Algebraically adds the signals from both vertical compartments and displays the sum.
 - CHOP:** Selects signals from both vertical compartments for display (dual trace). The display switches between both vertical compartment signals, during the sweep, at a one megahertz rate.
 - RIGHT:** Selects signals from the right vertical amplifier compartment for display.

- ② **TRIG SOURCE:** Selects the source of the internal trigger for the plug-in unit in the horizontal compartment.
 - LEFT:** Selects the left vertical compartment as the internal trigger source.
 - VERT MODE:** Internal trigger signals are determined by the VERT MODE switch.
 - RIGHT:** Selects the right vertical compartment as the internal trigger source.

- ③ **REDUCED SCAN**—Indicator light illuminates when in the Reduced Scan mode.

- ④ **INTENSITY**—Controls the brightness of the display.

- ⑤ **REDUCED SCAN**—Pull switch selects Reduces Scan operation; push for normal operation.

- ⑥ **READOUT**—Turns on the Readout system and controls the brightness of the Readout display. (Option 1 deletes this function.)

- ⑦ **GRATICULE ILLUM**—Controls the illumination of the graticule.

- ⑧ **BEAMFINDER**—When pressed, this switch limits the display to within the graticule area.

FRONT PANEL CONTROLS AND CONNECTORS (cont.)

- ⑨ PERSISTENCE—Controls the view time of the VAR PERSIST and FAST VAR PERSIST stored displays. Operation is locked out in the SAVE display mode.
- ⑩ ERASE—Initiates erase cycles; either MANual or PERIODIC.

 - MANual: When pressed, initiates an erase cycle to erase the stored display and provide a single-shot reset command to the plug-in time-base unit. Operation is locked out in SAVE display mode.
 - PERIODIC: Controls the time between automatic erase cycles. If the erase period ends during a sweep, the erasure is delayed till the end of that sweep. This control has a counterclockwise OFF detent position. Operation is locked out in the SAVE display mode.
- ⑪ FAST—Used in conjunction with the VAR PERSIST and BISTABLE storage selections to choose the fast transfer storage modes of either FAST VAR PERSIST or FAST BISTABLE.
- ⑫ VAR PERSIST—Selects the Variable Persistence storage mode. The stored display is of variable intensity dependent upon the setting of the STORAGE LEVEL, density of charge deposited when storing, etc. The stored display can be erased at a controllable, continuous rate determined by the setting of the PERSISTENCE control. When not being erased, the view time is limited by the natural bright fading of the storage target.
- ⑬ BISTABLE—Selects the BISTABLE storage mode. The stored display is substantially of two fixed intensity levels; written (bright) and unwritten (background). An erase cycle returns the display to the unwritten state.
- ⑭ POWER—Switch and indicator. Switch applies power to the instrument and the indicator illuminates to indicate the power is on.
- ⑮ CALIBRATOR—Positive going square wave or dc voltage selected by an internal jumper. Output voltage at pin jacks (4 V, 0.4 V, and 40 mV).
- ⑯ SAVE INTEN—Used in conjunction with SAVE to control the storage viewing intensity. At reduced intensity, the view time of the stored VAR PERSIST display is proportionately extended.
- ⑰ STORAGE LEVEL—Controls the voltage level on the storage targets. Adjusts writing speed in FAST BISTABLE, VAR PERSIST, and FAST VAR PERSIST.
- ⑱ SAVE—Selects the SAVE display mode. The stored display is retained at a controllable SAVE INTENSITY and the erase functions are locked out. The time-base unit is inhibited except when the SAVE mode is entered from STORE before a sweep occurs. If this is done, the display will wait in the STORE mode and enter SAVE automatically at the end of the next

FRONT PANEL CONTROLS AND CONNECTORS (cont.)

occurring sweep. This is referred to as the 'babysitting' mode.

- ①9 FAST LEVEL CENTER—Adjusts the voltage level of the FAST target relative to the viewing target and, therefore, the tracking of the STORAGE LEVEL for the two targets (Internal adjustment for instruments SN B150000 - up).
- ②0 STORE—Selects the STORE display mode.
- ②1 NON STORE—Selects conventional display mode. Storage system is inoperative.
- ②2 TRACE ROTATE—Adjusts alignment of the trace with the horizontal graticule line.
- ②3 FOCUS—Provides adjustment for display definition.
- ②4 CAMERA POWER—Three-pin connector on crt bezel provides power output and receives remote single-sweep reset signal from compatible camera systems.

REAR PANEL CONTROLS AND CONNECTORS

The following descriptions are referenced to Figure 1-3.

- ②5 FUSE—Line voltage fuse.
- ②6 REMOTE ERASE IN—Provides external connection for remote erase.
- ②7 EXT SS RESET IN—Remote single sweep reset.
- ②8 EXT Z AXIS IN—Input for intensity modulation of the crt display.
- ②9 VERT SIG OUT—Vertical signal selected by TRIG SOURCE switch (LEFT, RIGHT, ALT, and ADD).
- ③0 + GATE OUT—Gate signal selected by gate selector switch (Main, Auxiliary, and Delay).
- ③1 + SAWTOOTH OUT—Positive-going sawtooth from time-base unit.

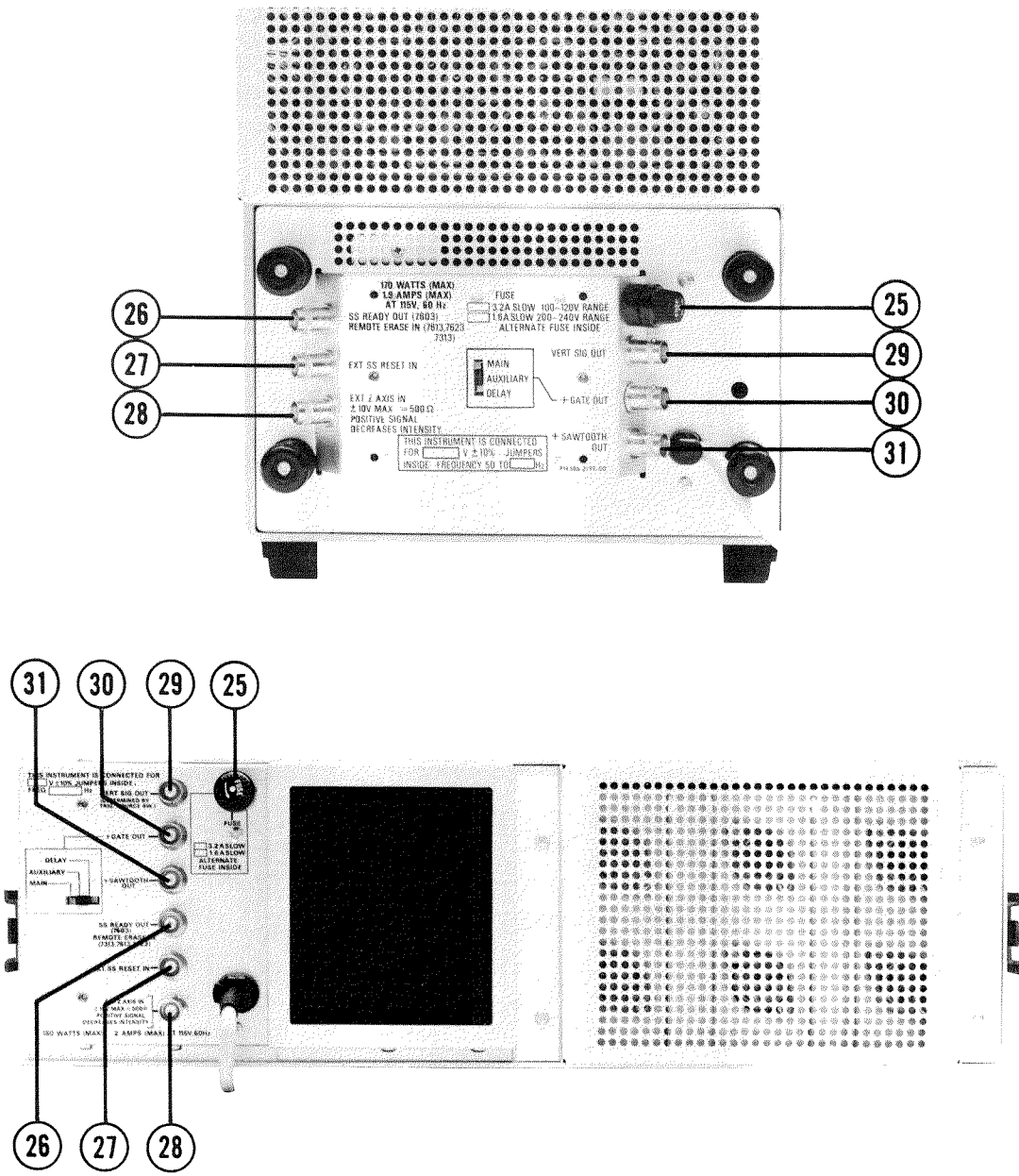

Figure 1-3. Rear panel controls and connectors.

OPERATING CHECKOUT

GENERAL

The following Operating Checkout provides a means of verifying instrument operation and basic calibration without removing the covers or making internal adjustments. Since it demonstrates the use of all controls and connectors, it can also be used to provide basic training on the operation of this instrument. If re-calibration of the 7633 appears to be necessary, see the Calibration procedure in the Service manual. If re-calibration of a plug-in unit is indicated, see the Instruction manual for the appropriate plug-in unit.

SET-UP INFORMATION

1. Set the front-panel controls as follows:

INTENSITY	Counterclockwise
FOCUS	Midrange
GRATICULE ILLUM	As desired
VERT MODE	LEFT
TRIG SOURCE	VERT MODE
Display Selection	NON STORE
REDUCED SCAN	Off
READOUT INTENSITY	Off

Momentary switches (BEAM FINDER and MAN ERASE) are not actuated unless they are pressed.

2. Connect the 7633 to a power source which meets the voltage and frequency requirements of this instrument. The applied voltage should be near the center of the voltage range marked on the rear panel (see Operating Voltage in this section for information on converting this instrument from one operating voltage to another).

3. Install Tektronix 7A-series amplifier units (with one megohm input impedance) into both the left and right vertical plug-in compartments. Install a 7B-series time-base unit into the horizontal compartment. Be sure that plug-in units are calibrated.

4. Push the POWER switch to turn the instrument on. Allow several minutes warmup before proceeding.

5. Set both vertical units for a deflection factor of two volts/division and center the vertical position controls. Set both vertical units for AC input coupling.

6. Set the time-base unit for a sweep rate of one millisecond/division in the auto, internal trigger mode.

7. Advance the INTENSITY control until the trace is at the desired viewing level (near midrange). Advance the READOUT INTENSITY control (out of the detent position) until the readout display is at the desired viewing level. (Option 1 deletes the Readout system.)

DISPLAY FOCUS

8. Adjust the FOCUS adjustment for a sharp, well-defined display over the entire trace length. If a properly focused display cannot be obtained with the FOCUS adjustment, the internal Astigmatism adjustment must be reset; see the Calibration section of the Service manual.

TRACE ALIGNMENT

9. Position the trace with the left vertical unit position control so it coincides with the center horizontal line of the graticule. If the trace is not parallel to the center horizontal line of the graticule, see Trace Rotation adjustment procedure in Calibration section.

10. Connect the 4 V calibration pin-jack to the input of the left vertical unit with a BNC to pin-jack cable (supplied accessory) and adjust the time-base unit for a stable display.

GRATICULE ILLUMINATION

11. Rotate the GRATICULE ILLUM control throughout its range and notice that the illumination of the graticule lines increases as the control is turned clockwise (most obvious with tinted filter installed). Set the control so the graticule lines are illuminated as desired.

VERTICAL DEFLECTION SYSTEM

12. Set both vertical units for a deflection factor of one volt/division. The display amplitude should be four divisions. Note the exact display amplitude for step 15.

13. Notice that the position control of only the left vertical unit has an effect on the position of the display. Position the display to the upper half of the graticule.

14. Press the RIGHT button of the VERT MODE switch. Remove the calibrator signal from the left vertical and connect it to the right vertical. The display amplitude should be four divisions within 0.12 division. Note the exact display amplitude for the next step.

15. A correct display in both steps 12 and 14 indicates that the 7633 Vertical Deflection System and the vertical plug-in units are calibrated. If the displays noted previously are both outside the given tolerance in the same direction (i.e., high or low), the Vertical Gain or 4 Volts calibrator adjustment may need re-adjustment. Otherwise, check the calibration of the vertical plug-in units.

16. Notice that the position control of only the right vertical unit has an effect on the position of the display. Position the display to the lower half of the graticule. Set both vertical units for a deflection factor of two volts/division. Connect the calibrator signal to both vertical units by using a dual input coupler or a BNC T connector.

17. Press the ALT pushbutton of the VERT MODE switch. Notice that two traces are displayed on the crt. The top trace is produced by the left vertical unit and the bottom trace is produced by the right vertical unit. Set the sweep rate to 50 milliseconds/division. Notice that the display alternates between the left and right vertical units after each sweep. Turn the sweep rate switch throughout its range. Notice

Operating Instructions—7633/R7633 Operators

that the display alternates between vertical units at all sweep rates.

18. Press the CHOP push button of the VERT MODE switch. Turn the sweep rate switch throughout its range. Notice that a dual-trace display is presented at all sweep rates, but unlike ALT both vertical units are displayed on each sweep in a time-sharing manner. Return the sweep rate to 0.5 millisecond/division.

19. Press the ADD push button of the VERT MODE switch. The display should be the algebraic sum of both signals. Notice that the position control of either vertical unit moves the display. Return the VERT MODE switch to the LEFT and disconnect the signal to the right amplifier unit.

20. Pull the REDUCED SCAN switch and notice that the REDUCED SCAN indicator light illuminates and that the display is reduced in size by 50 percent.

21. Repeat steps 12 through 19; measuring and observing the display amplitudes on the REDUCED SCAN graticule area.

22. Press the REDUCED SCAN switch. The remainder of this familiarization procedure can be performed in the REDUCED SCAN mode if the appropriate changes are made.

TRIGGERING

23. Center the display on the crt with the left vertical unit position control. Disconnect the input signal from the right vertical unit input connector. Sequentially press all of the VERT MODE switch buttons. Notice that a stable display (if necessary, adjust the trigger level control) can be obtained in all positions of the VERT MODE switch (straight line in RIGHT position).

24. Press the LEFT push button of the TRIG SOURCE switch. Again, sequentially press all of the VERT MODE buttons. Notice that the display is again stable in all positions, as in the previous step.

25. Press the RIGHT push button of the TRIG SOURCE switch. Sequentially press all of the VERT MODE buttons and notice that a stable display cannot be obtained in any position. This is because there is no input signal connected to the right vertical unit. Return the TRIG SOURCE switch to VERT MODE. Remove calibrator signal from left vertical unit and connect it to right vertical unit.

26. Center the display on the crt with the right vertical unit position control. Sequentially press all the VERT MODE switch buttons. Notice that a stable display (if necessary, adjust the trigger level control) can be obtained in all positions of the VERT MODE switch (straight line in RIGHT position).

27. Press the RIGHT push button of the TRIG SOURCE switch. Again, sequentially press all of the VERT MODE buttons. Notice that the display is again stable in all positions as in the previous step.

28. Press the LEFT push button of the TRIG SOURCE switch. Sequentially press all of the VERT MODE buttons and notice that a stable display cannot be obtained in any position since no signal is connected to the input of the left amplifier unit.

HORIZONTAL DEFLECTION SYSTEM

29. Disconnect all input signals and set the TRIG SOURCE to VERT MODE. Position the start of the sweep to the left graticule line with the time-base unit position control.

30. Connect a 10X probe to the input of the right vertical unit. Set the right vertical unit for a deflection factor of 10 volts/division and set the VERT MODE switch to RIGHT. Set the time-base unit for a sweep rate of five milliseconds/division.

NOTE

The following step is based on an accurate 60-hertz line frequency. For other line frequencies, this procedure will need to be changed accordingly.

31. Connect the probe tip to a line-voltage source. The display should show three complete cycles over the 10 divisions within 0.3 division. A correct display indicates that the 7633 Horizontal Deflection System and the time-base plug-in unit are correctly calibrated. If the display is outside the given tolerance, either the 7633 or the time-base unit needs to be recalibrated. Refer to the Calibration section of the Service manual, and to the time-base unit manual for adjustment procedure.

32. Disconnect the probe from the line-voltage source and the right vertical unit. Set the VERT MODE switch to LEFT and set the time-base unit for a sweep rate of 0.5 millisecond/division. Disconnect all cables.

STORAGE OPERATION

33. Connect the 4 V Calibrator signal to the input connector of the left vertical unit and set the deflection factor for one volt/division. Set the time-base unit for single-sweep operation at 0.5 millisecond/division. Be sure the time-base unit is triggered and the INTENSITY control is set to midrange.

34. Press the STORE and BISTABLE push buttons.

35. Press the MANual ERASE push button. If the calibrator waveform does not store, increase the INTENSITY slightly and press the ERASE button again. If necessary, repeat this sequence until a stored display is obtained.

36. Press the SAVE push button. The waveform stored in the previous step should remain on the crt. It may be necessary to adjust the SAVE INTEN control to view the display. Turn the SAVE INTEN control throughout its range and observe its effect on the display: from dark at the counterclockwise end to bright screen at the clockwise end.

37. Press the ERASE button and notice that the display cannot be erased. The erase function is locked out in the SAVE mode.

Operating Instructions—7633/R7633 Operators

38. Set the STORAGE LEVEL and PERSISTENCE controls fully counterclockwise. Press the STORE, then the VAR PERSIST push buttons. Observe that an erase cycle and sweep occurs (when switching between the BISTABLE and VAR PERSIST modes) and that the screen goes dark except for the stored display.

39. Slowly turn the PERSISTENCE control clockwise and notice that the stored display fades into the background. (A background lighting will be observed as the PERSISTENCE control is advanced clockwise. This is caused by the positive persistence pulses being applied to the Front storage mesh.) The PERSISTENCE control adjusts the length of time the stored display is retained in the VAR PERSIST mode. Return the PERSISTENCE control to its fully counterclockwise position.

40. Press the ERASE push button, then set the PERSISTENCE control to midrange just long enough for the display to fade out. Quickly return the PERSISTENCE control to its counterclockwise end. Slowly increase the STORAGE LEVEL (clockwise) and notice that the faded display again becomes visible against a background that begins to brighten. This background lighting results from the increased voltage (STORAGE LEVEL) on the Front Mesh storage surface. Eventually, the unstored area of the Front Mesh will become brighter (charge positive) until the stored (written) area can no longer be distinguished from the bright background. The 'view time' is the length of time the display is viewable from the moment of signal storage until it is obscured by the brightness of the background as described above.

As the STORAGE LEVEL is increased (turned clockwise), the writing speed (sensitivity of the Front Mesh storage surface to faster, smaller-amplitude signals) increases. However, as the writing speed is increased, there is a corresponding reduction of the 'view time'.

41. Turn the PERSISTENCE, STORAGE LEVEL, and INTENSITY controls fully counterclockwise and set the time-base unit for auto triggering at a sweep rate of 0.5 second/division.

42. Set the PERSISTENCE control to midrange and slowly increase the INTENSITY (clockwise) until the trace appears. Vary the PERSISTENCE control setting and notice that the trace can be made to build up or to fade more quickly, depending on the control setting. Varying the INTENSITY control also affects the display in the same manner. Return the PERSISTENCE control to midrange and slowly decrease the INTENSITY to the point where the trace just extinguishes. Adjust the STORAGE LEVEL control clockwise and notice that the trace becomes visible again. This is because the writing speed has been increased as described in step 40.

43. Turn the PERSISTENCE, STORAGE LEVEL, and INTENSITY controls fully counterclockwise and set the time-base unit for auto triggering at a sweep rate of 0.5 millisecond/division.

44. Press the STORE, BISTABLE, and FAST push buttons.

45. Press the ERASE push button and notice that the screen background appears to alternate between bright and dim. This indicates that the sweep and transfer functions are operating—the sweep occurs (writing on the Fast Mesh), then the written display is transferred to the Front Mesh. The ERASE control should still be in the MANUAL (detent) position so no erase cycle occurs.

Operating Instructions—7633/R7633 Operators

46. Press the ERASE push button; then, slowly increase the INTENSITY control (clockwise) until the display stores. Notice that each sweep is stored without erasing the previously stored sweep. This is more easily observed if the vertical position control setting is varied between sweeps.
47. Press the ERASE push button and notice that the display is erased.
48. Set the time-base unit for single sweep and press the ERASE push button. Notice that only one sweep is stored.
49. Change the setting of the vertical position control and initiate another sweep by pressing the reset button on the time-base unit. Notice that the new sweep is stored along with the one stored in the previous step.
50. Alternately press the ERASE push button and reduce the INTENSITY to the point where the display just barely fails to store.
51. Alternately increase the STORAGE LEVEL (clockwise) and press the ERASE push button. Notice that as the STORAGE LEVEL is increased, that the display begins to store. This is because the STORAGE LEVEL control setting determines the amount of signal transferred from the Fast Mesh to the Front Mesh in the FAST storage modes (both BISTABLE FAST and VAR PERSIST FAST).
52. The FAST VAR PERSIST mode operates exactly as outlined for the VAR PERSIST mode except that the sweep and transfer functions are operative as described in FAST BISTABLE operation. Because the sweep is first written on the Fast Mesh and transferred to the Front Mesh, faster signals can be stored.
53. Set the time-base unit for auto triggering and set the 7633 for BISTABLE operation (disengage the FAST push button by pressing and releasing).
54. Set the INTENSITY control to the one o'clock position. Turn the ERASE control out of the detent position and notice that erase cycles occur automatically and with increasing frequency as the control is turned toward its clockwise end. This is the PERIODIC ERASE function.
55. Return the ERASE control to the detent (off) position and set the time-base unit for single sweep and external triggering. Turn the SAVE INTEN control fully counterclockwise.
56. Press the ERASE push button. Notice that no sweep occurs.
57. Press the SAVE push button. Notice that no sweep occurs. This is the 'Babysitting' mode. Since no trigger was available, the sweep did not run so the system waits in the STORE mode.
58. Set the time-base unit to internal trigger and notice that the screen goes dark. This indicates a sweep occurred and that the system has entered the SAVE mode.
59. Turn the SAVE INTEN control clockwise and notice that the stored display becomes visible.

Operating Instructions—7633/R7633 Operators

60. Press NON STORE and set the time-base unit for auto triggering.

BEAMFINDER

61. Set the deflection factor of the left vertical unit to 0.1 volt/division. Notice that a square-wave display is not visible, since the deflection exceeds the scan area of the crt.

62. Press and hold the BEAMFINDER switch. Notice that the display is returned to the viewing area in compressed form. Increase the vertical and horizontal deflection factors until the display is reduced to about two divisions vertically and horizontally (when the horizontal unit is operated in the time-base mode, change only the deflection factor of the vertical unit). Adjust the position controls of the displayed vertical unit and the time-base unit to center the compressed display about the center lines of the graticule. Release the BEAMFINDER switch. Notice that the display remains within the viewing area.

Z-AXIS INPUT

63. If an external signal is available (two volts peak-to-peak minimum at two megahertz or less), the function of the EXT Z AXIS input can be demonstrated. Connect the external signal to both the input of the right vertical unit and the EXT Z AXIS connector with two BNC cables and a BNC T connector. Set the VERT MODE switch to RIGHT and set the vertical unit for a deflection factor of one volt/division. Set the time-base unit for a sweep rate which displays several cycles of the signal. Adjust the amplitude of the signal generator until intensity modulation is visible on the display. The positive peaks of the waveform should be blanked out and the negative peaks intensified. Notice that the setting of the INTENSITY control determines the amount of intensity modulation that is visible.

64. Disconnect the signal from the EXT Z AXIS connector, but leave it connected to the right vertical unit input. Check that peak-to-peak amplitude of the displayed signal is four divisions maximum. This completes the Operating Checkout procedure for the 7633.

GENERAL OPERATING INFORMATION

INTENSITY CONTROL

The setting of the INTENSITY control may affect the correct focus of the display. Slight re-adjustment of the FOCUS adjustment may be necessary, when the intensity level is changed. To protect the crt phosphor; do not turn the INTENSITY control higher than necessary to provide a satisfactory display. The light filters reduce the observed light output from the crt. When using these filters, avoid advancing the INTENSITY control to a setting that may burn the phosphor. When the highest intensity display is desired, remove the filters and use only the clear faceplate protector (permanently installed behind bezel). Apparent trace intensity can also be improved in such cases by reducing the ambient light level or using a viewing hood. Also, be careful that the INTENSITY control is not set too high when changing the time-base unit sweep rate from a fast to a slow sweep rate, or when changing to the X-Y mode of operation. The instrument incorporates protection circuitry which automatically reduces the display intensity to a lower level when the time-base unit is set to a slow sweep rate. This reduces the danger of damaging the crt phosphor at these lower sweep rates.

DISPLAY FOCUS

The FOCUS adjustment allows control for best definition of the crt display. The Readout intensity should be turned on when adjusting the focus. Slight re-adjustment of this control may be necessary as display conditions change. If a properly focused display cannot be obtained with the FOCUS adjustment, the internal Astigmatism adjustment must be re-set; see the Calibration section of the Service manual.

GRATICULE

The graticule of the 7633 is marked on the inside of the faceplate of the crt, providing accurate, non-parallax measurements. The graticule is divided into eight vertical and ten horizontal divisions. Each full scan division is 0.9 centimeter square divided into five minor divisions. A Reduced Scan graticule is etched in the center of the full scan graticule. Each Reduced Scan division is exactly half (0.45 centimeter) of a full scan division. The vertical gain and horizontal timing of the plug-in units are calibrated to the graticule so accurate measurements can be made from the crt. The illumination of the graticule lines can be varied with the GRATICULE ILLUM control.

Fig. 1-4 shows the graticule of the 7633 and defines the various measurement lines. The terminology defined here will be used in all discussions involving graticule measurements. Notice the 0%, 10%, 90%, and 100% markings on the left side of the graticule. These markings are provided to facilitate rise-time measurements.

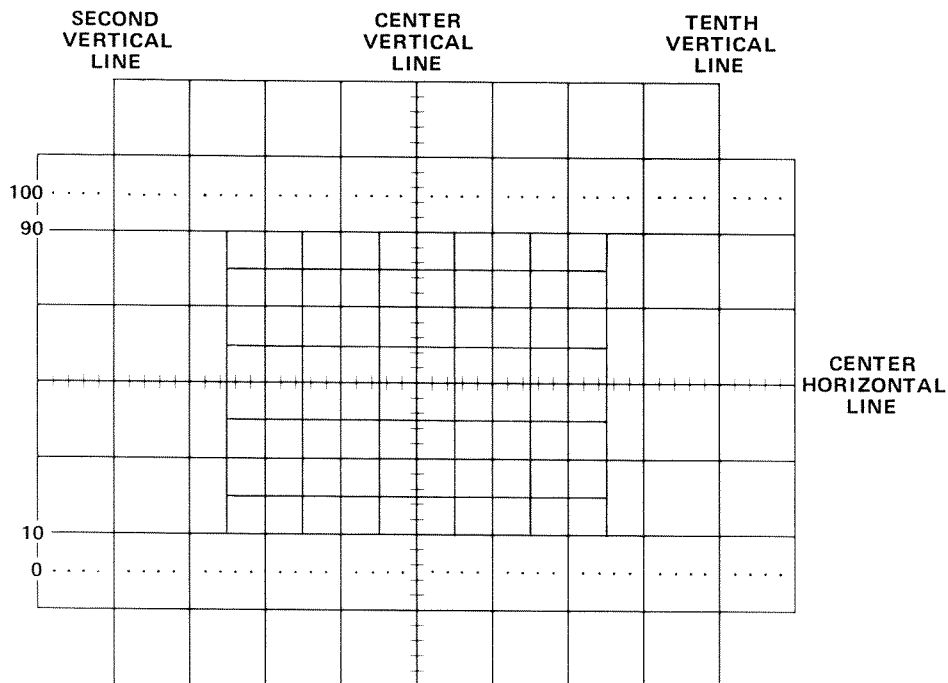

Figure 1-4. Definition of measurement lines on the graticule.

LIGHT FILTER

The tinted filter provided with the 7633 minimizes light reflections from the face of the crt to improve contrast when viewing the display under high ambient light conditions. This filter should be removed for waveform photographs or when viewing high writing rate displays. To remove the filter, pull outward on the bottom of the plastic crt mask and remove it from the crt bezel. Remove the tinted filter; leave the clear plastic faceplate protector installed and replace the bezel. The faceplate protector should be left in place at all times to protect the crt faceplate from scratches.

An optional mesh filter is available for use with the 7633. This filter provides shielding against radiated EMI (electro-magnetic interference) from the face of the crt. It also serves as a light filter to make the trace more visible under high ambient light conditions. The mesh filter fits in place of the plastic crt mask and the tinted filter. The filter can be ordered by Tektronix Part No. 378-0603-00.

BEAMFINDER

The BEAMFINDER switch provides a means of locating a display which overscans the viewing area either vertically or horizontally. When the BEAMFINDER switch is pressed and held, the display is compressed within the graticule area. Release the BEAMFINDER switch to return to a normal display. To locate and reposition an overscanned display, use the following procedure:

1. Press and hold the BEAMFINDER switch.
2. Increase the vertical and horizontal deflection factors until the vertical deflection is reduced to about two divisions and the horizontal deflection is reduced to about four divisions (the horizontal deflection needs to be reduced only when in the X-Y mode of operation).
3. Adjust the vertical and horizontal position controls to center the display about the vertical and horizontal center lines of the graticule.
4. Release the BEAMFINDER switch; the display should remain within the viewing area.

REDUCED SCAN MODE

The Reduced Scan mode increases the stored writing speed (in centimeters/microsecond) to about four times that of the full scan mode. This is achieved by increasing the crt cathode voltage from 1.5 kilovolts in the full scan mode to 3 kilovolts in the Reduced Scan mode, which results in higher beam energy and a smaller spot size.

The calibrated division size changes from 0.9 centimeters in the full scan mode to 0.45 centimeters in Reduced Scan. Calibrated measurements are confined to the inner 8 x 10 Reduced Scan divisions of the graticule area.

READOUT MODES (Option 1 deletes)

The characters of the readout display are written by the crt beam on a time-share basis with signal waveforms. The Readout System operates in a free-running mode to randomly interrupt the waveform display to present the readout characters. The Readout System can also operate in a GATE TRIG'D mode; no readout signal is produced until after the sweep has occurred. In this mode the sweep must run to have a readout display. Switch 2110, located on the Readout board, changes the Readout modes. See Figure 1-5 for location of S2110.

DISPLAY PHOTOGRAPHY

A permanent record of the crt display can be obtained with an oscilloscope camera system. The instruction manuals for the Tektronix Oscilloscope Cameras include complete instructions for obtaining waveform photographs. The following information applies only to the 7633 Oscilloscope.

The crt bezel of the 7633 provides integral mounting for Tektronix Oscilloscope Cameras. Three pins, located on the crt bezel, connect power to compatible camera systems. These pins also sense control signals from Tektronix automatic cameras to permit camera-controlled single-shot photography (see the camera manual for further information).

Photographs of waveforms stored in the VAR PERSIST mode are obtained in the same manner as those taken in normal operation. However, to obtain satisfactory photographs of a stored BISTABLE display, it is often necessary to switch into the SAVE mode and use reduced intensity.

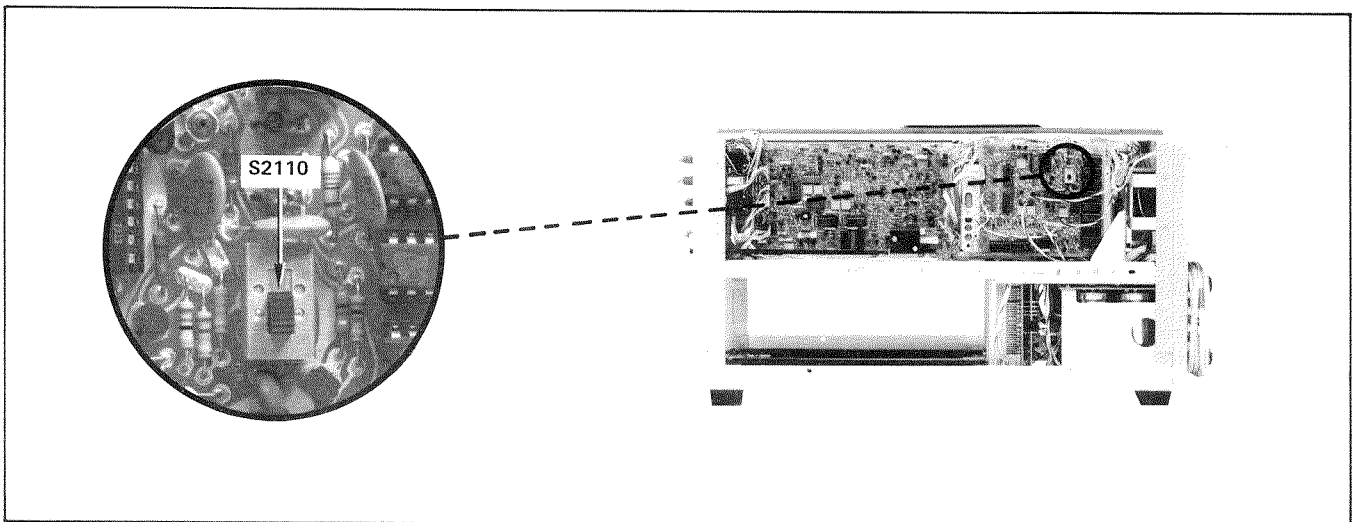

Figure 1-5. Location of Readout Mode switch.

STORAGE

The 7633 Transfer Storage Oscilloscope has four selectable storage modes (listed in order of increasing writing speed): BISTABLE, VAR PERSIST, FAST BISTABLE, and FAST VAR PERSIST. The storage writing speed in all storage modes is affected by the setting of the INTENSITY control. The STORAGE LEVEL control also adjusts writing speed in all storage modes except BISTABLE. The STORAGE LEVEL control adjusts the bias voltage on the Front Mesh in VAR PERSIST mode and on the Fast Mesh in the FAST modes.

Fastest writing speed is obtained with the INTENSITY control set to maximum without blooming the trace and the STORAGE LEVEL set in the two o'clock position.

The erase cycle removes any previous display from the Front (view) Mesh and prepares this mesh for receipt of a waveform. Erase cycles are initiated by pressing the MANUAL knob or by rotating it out of the MAX detent position for PERIODIC erasure. Frequency of PERIODIC ERASE cycles can be controlled in the 2 - 10 second range. If a sweep is in progress when the PERIODIC ERASE cycle occurs, the erase cycle is delayed until the end of sweep. Thus, the PERIODIC ERASE control can be used to set up an erase-after-sweep operation for slower periodic sweeps. A Single Sweep Reset is sent to the time-base unit at the end of each erase cycle. Consequently, if the time-base unit is in the single-sweep mode, it is automatically armed to run once following each erase cycle.

REMOTE ERASE is commanded by a ground closure applied to the rear panel input.

BISTABLE MODE

In the BISTABLE storage mode, the INTENSITY control adjusts for optimum stored display. Slower signals require less intensity to store than faster signals. The STORAGE LEVEL and PERSISTENCE controls do not operate in the BISTABLE mode.

VARIABLE PERSISTENCE MODE

In the VAR PERSIST mode, the INTENSITY and STORAGE LEVEL controls adjust the writing speed and the PERSISTENCE control adjusts the length of time the stored signal is visible before it fades into the background.

FAST MODES

Time-base unit operation is modified by the Storage system in the FAST storage modes to permit individual sweeps to recur at about one second intervals. This permits the Fast Mesh to be prepared between sweeps. After each sweep, the signal is transferred from the Fast Mesh to the Front Mesh for viewing. Then, the Fast Mesh is prepared again for the next sweep and the cycle repeats.

If an erase cycle occurs, Fast Mesh preparation takes place during the erase cycle. However, it is not necessary to ERASE for the sweep and transfer functions to cycle. For instance, if the time-base

unit is set for single-sweep, multiple sweeps can be stored by pressing the reset button on the time-base unit. If the time-base unit is set for auto triggering, the sweep and transfer functions automatically operate in a cyclical fashion. After each sweep, the display transfers to the Front Mesh for viewing and the Fast Mesh is prepared for the next sweep. Since no erase cycle is generated, multiple sweeps can be stored automatically in this manner. This can be more easily observed if the vertical position is varied between sweeps.

FAST BISTABLE MODE

This mode operates the same as BISTABLE except the display is written on the Fast Mesh and transferred to the Front Mesh for viewing as described above. Therefore, the STORAGE LEVEL control setting affects the stored writing speed.

FAST VARIABLE PERSISTENCE MODE

This mode combines the operation of both VAR PERSIST and FAST BISTABLE. The PERSISTENCE control adjusts the view time, the STORAGE LEVEL adjusts writing speed, and the display will automatically sweep and transfer when the time-base unit is set for auto triggering.

SAVE MODE

The SAVE mode can be entered from either storage mode to retain a stored display indefinitely. The intensity of the stored display in the SAVE mode is adjusted by the SAVE INTEN control. When the SAVE mode is selected, the ERASE function is locked out to prevent erasure of the stored display. Also, the time-base unit is inhibited except when the SAVE mode is entered from STORE before a sweep occurs. If this is done, the display will wait in the STORE mode until a sweep occurs. When a sweep occurs the display will automatically enter SAVE. This is referred to as the 'Babysitting' mode.

CARE OF STORAGE SCREEN

The following precautions will prolong the useful storage life of the crt screen used in this instrument.

1. Use minimum beam intensity to produce a clear, well-defined display.
2. Use minimum SAVE INTEN when storing images for extended periods of time.
3. Avoid repeated use of the same area of the screen. If a particular display is being stored repeatedly, change the vertical position occasionally to use other portions of the display area.

VERTICAL MODE

LEFT AND RIGHT MODE

When the LEFT or RIGHT button of the VERT MODE switch is pressed, only the signal from the plug-in unit in the selected compartment is displayed.

ALTERNATE MODE

The ALT position of the VERT MODE switch produces a display which alternates between the plug-in units in the left vertical and right vertical compartments with each sweep of the crt. Although the ALT mode can be used at all sweep rates, the CHOP mode provides a more satisfactory display at sweep rates below about 20 milliseconds/division. At these slower sweep rates, alternate-mode switching becomes visually perceptible.

NOTE

This instrument will not operate in the ALT mode if the horizontal plug-in unit is not operated in the time-base mode.

The TRIG SOURCE switch allows selection of the triggering for an alternate display. When this switch is set to the VERT MODE position, each sweep is triggered by the signal being displayed on the crt. This provides a stable display of two unrelated signals, but does not indicate the time relationship between the signals. In either the LEFT or RIGHT positions of the TRIG SOURCE switch, the two signals are displayed showing true time relationship. However, if the signals are not time-related, the display from the plug-in unit which is not providing a trigger signal will appear unstable on the crt.

CHOPPED MODE

The CHOP position of the VERT MODE switch produces a display which is electronically switched between channels at a one-megahertz rate. In general, the CHOP mode provides the best display at sweep rates lower than about 20 milliseconds/division, or whenever dual-trace single-shot phenomena are to be displayed. At faster sweep rates, the chopped switching becomes apparent and may interfere with the display.

Correct internal triggering for the CHOP mode can be obtained in any of the three positions of the TRIG SOURCE switch. When the TRIG SOURCE switch is set to VERT MODE, the internal trigger signals from the vertical plug-in units are algebraically added and the time-base unit is triggered from the resultant signal. Use of the LEFT or RIGHT trigger-source positions triggers the time-base unit on the internal trigger signal from the selected vertical unit only. This allows two time-related signals to be displayed showing true time relationship. However, if the signals are not time-related, the display for the channel which is not providing the trigger signal will appear unstable. The CHOP mode can be used to compare two single-shot, transient, or random signals which occur within the time interval determined by the time-base unit (ten times selected sweep rate). To provide correct triggering, the display which provides the trigger signal must precede the second display in time. Since the signals show true time-relationship, time-difference

measurements can be made from the display.

ALGEBRAIC ADDITION

The ADD position of the VERT MODE switch can be used to display the sum or difference of two signals, for common-mode rejection to remove an undesired signal, or for dc offset (applying a dc voltage to one channel to offset the dc component of a signal on the other channel). The common-mode rejection ratio between the vertical plug-in compartments of the 7633 is greater than 20:1 at 50 megahertz. The rejection ratio increases to 100:1 at dc.

The overall deflection factor on the crt in the ADD mode is the resultant of the algebraic addition of the signals from the two vertical plug-in units. It is difficult to determine the voltage amplitude of the resultant display unless the amplitude of the signal applied to one of the plug-in units is known. This is particularly true when the vertical units are set to different deflection factors, since it is not obvious which portion of the display is a result of the signal applied to either plug-in unit. Also, the polarity and repetition rate of the applied signals enters into the calculation.

The following general precautions should be observed to provide the best display when using the ADD mode:

1. Do not exceed the input voltage rating of the plug-in units.
2. Do not apply large signals to the plug-in inputs. A good rule to follow is not to apply a signal which exceeds an equivalent of about eight times the vertical deflection factors. For example, with a vertical deflection factor of 0.5 volt/division, the voltage applied to that plug-in unit should not exceed 4 volts. Larger voltages may result in a distorted display.
3. To ensure the greatest dynamic range in the ADD mode, set the position controls of the plug-in units to a setting which would result in a mid-screen display if viewed in the LEFT or RIGHT positions of the VERT MODE switch.
4. For similar response from each channel, set the plug-in units for the same input coupling.

TRIGGER SOURCE

The TRIG SOURCE switch allows selection of the internal trigger signal for the time-base unit. For most applications, this switch can be set to the VERT MODE position. This position is the most convenient, since the internal trigger signal is automatically switched as the VERT MODE switch is changed, or as the display is electronically switched between the left vertical and right vertical plug-in units in the ALT position of the VERT MODE switch. It also provides a usable trigger signal in the ADD or CHOP positions of the VERT MODE switch, since the internal trigger signal in these modes is the algebraic sum of the signals applied to the vertical plug-in units. Therefore, the VERT MODE position ensures that the time-base unit receives a trigger signal regardless of the VERT MODE switch setting, without the need to change the trigger source selection.

Operating Instructions—7633/R7633 Operators

If correct triggering for the desired display is not obtained in the VERT MODE position, the LEFT or RIGHT positions can be used to obtain the trigger signal from either the left vertical or right vertical plug-in unit. The internal trigger signal is obtained from the selected vertical compartment, whether the plug-in unit in that compartment is selected for display on the crt or not. If the internal trigger signal is obtained from one of the vertical units, but the other vertical unit is selected for display, the internal trigger signal must be time-related to the displayed signal in order to obtain a triggered (stable) display.

X-Y OPERATION

For some applications, it is desirable to display one signal versus another (X-Y) rather than against time (internal sweep). The flexibility of the plug-in units available for use with the 7633 provides a means for applying an external signal to the horizontal deflection system for this type of display. Some of the 7B-series time-base units can be operated as amplifiers in addition to their normal use as time-base generators. This feature allows an external signal to provide the horizontal deflection on the crt. For most of the time-base units with the amplifier function, the X (horizontal) signal can be connected either to an external input connector on the time-base unit or it can be routed to the time-base unit through the internal triggering system (see time-base instruction manual for details). If the latter method is used, the TRIG SOURCE switch must be set so that the X (horizontal) signal is obtained from one of the vertical units and the Y (vertical) signal is obtained from the other vertical unit. The advantages of using the internal trigger system to provide the X signal are that the attenuator switch of the amplifier unit providing the horizontal signal determines the horizontal deflection factor to allow full-range operation. The plug-in units do not have to be removed between compartments when X-Y operation is desired.

Another method of obtaining an X-Y display is to install an amplifier plug-in unit in the horizontal plug-in compartment (check amplifier unit gain as given in the plug-in instruction manual to obtain calibrated horizontal deflection factors). This method provides the best X-Y display, particularly if two identical amplifier units are used, since both the X and Y input systems will have the same delay time, gain characteristics, input coupling, etc. For further information on obtaining X-Y displays, see the plug-in unit manuals. Also, the reference books listed under Applications provide information on X-Y measurements and interpreting the resultant lissajous displays.

INTENSITY MODULATION

Intensity (Z-axis) modulation can be used to relate a third item of electrical phenomena to the vertical (Y-axis) and the horizontal (X-axis) coordinates without affecting the waveshape of the displayed signal. The Z-axis modulating signal applied to the crt circuit changes the intensity of the displayed waveform to provide this type of display. 'Gray scale' intensity modulation can be obtained by applying signals which do not completely blank the display. Large amplitude signals of the correct polarity will completely blank the display; the sharpest display is provided by signals with a fast risetime and fall. The voltage amplitude required for visible trace modulation depends upon the setting of the INTENSITY control. A two-volt peak-to-peak signal will completely blank the display even at high intensity levels. Lower amplitude signals can be used to only change the trace brightness rather than completely blank the display. Negative-going modulating signals increase the display intensity and positive-going modulating signals decrease the

Operating Instructions—7633/R7633 Operators

display intensity. Useful input frequency range is dc to 10 megahertz (input voltage derating necessary above two megahertz). The maximum input voltage should be limited to 10 volts (dc plus peak ac).

Time markers applied to the EXT Z AXIS input connector provide a direct time reference on the display. With uncalibrated horizontal sweep or external horizontal mode operation, the time markers provide a means of reading time directly from the display. However, if the markers are not time-related to the displayed waveform, a single-sweep display should be used (for internal sweep only) to provide a stable display.

RASTER DISPLAY

A raster-type display can be used to effectively increase the apparent sweep length. For this type of display, the trace is deflected both vertically and horizontally by sawtooth signals. This is accomplished in the 7633 by installing a 7B-series time-base unit in one of the vertical plug-in compartments. Normally, the time-base unit in the vertical compartment should be set to a slower sweep rate than the time-base unit in the horizontal compartment; the number of horizontal traces in the raster depends upon the ratio between the two sweep rates. Information can be displayed on the raster using several different methods. In the ADD position of the VERT MODE switch, the signal from an amplifier unit can be algebraically added to the vertical deflection. With this method, the vertical signal amplitude on the crt should not exceed the distance between the horizontal lines of the raster. Another method of displaying information on the raster is to use the EXT Z AXIS input to provide intensity modulation of the display. This type of raster display could be used to provide a television-type display. Complete information on operation using the Z-axis feature is given under Intensity Modulation.

To provide a stable raster display, both time-base units must be correctly triggered. Internal triggering is not provided for the time-base units when they are in the vertical compartments; external triggering must be used. Also, blanking is not provided from the time-base units when they are installed in a vertical compartment. To blank out the retrace portion from the time-base unit in the vertical compartment, special connections must be made from this time-base unit to the blanking network of the 7633. If this mode of operation is desirable, contact your local Tektronix Field Office or representative for specific information on obtaining blanking with the specific time-base unit being used in the vertical compartment.

CALIBRATOR

GENERAL

The internal calibrator of the 7633 provides a convenient signal source for checking basic vertical gain and for adjusting probe compensation as described in the probe instruction manual. In addition, the calibrator can be used as a convenient signal source for application to external equipment.

VOLTAGE

The calibrator provides accurate output voltages of 40 millivolts, 0.4 volt, and 4 volts at the three front-panel pin-jack connectors into high-impedance loads. Output resistance is approximately 50 ohms

Operating Instructions—7633/R7633 Operators

at the 40 mV and 0.4 V pin jacks and approximately 450 ohms at the 4 V pin jack.

CURRENT

A 40-milliampere, one-kilohertz output current is provided when the optional current-loop accessory (Tektronix Part No. 012-0259-00) is connected between the 4 V pin jack and ground. This output can be used to check and calibrate current-measuring probe systems.

WAVESHAPE

The square-wave output signal of the calibrator can be used as a reference waveshape when checking or adjusting the compensation of passive, high-resistance probes. Since the square-wave output from the calibrator has a flat top, any distortion in the displayed waveform is due to the probe compensation. Dc voltage output is also available by changing a jumper on the calibrator board; see Figure 1-6.

SIGNALS OUT

VERTICAL SIGNAL

The VERT SIG OUT connector provides a sample of the vertical deflection signal. The source of the output signal is determined by the TRIG SOURCE switch. The source will follow the setting of the TRIG SOURCE switch. When the TRIG SOURCE is in the VERT MODE the output will follow the VERTICAL MODE switch. In the CHOP mode the signals are added. The output signals are LEFT, ALT, ADD, and RIGHT. The output signal into 50 ohms is about 25 millivolts/division of the vertical signal displayed on about 0.5 volts/division of the vertical signal displayed on the systems crt.

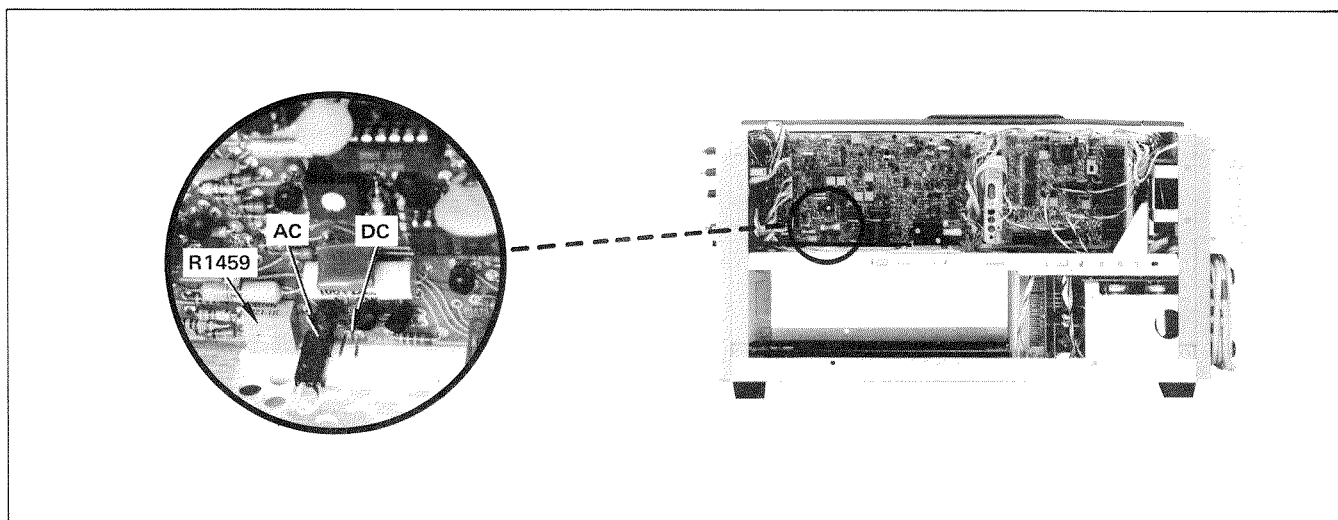

Figure 1-6. Location of Calibrator jumper on Storage circuit board.

+ GATE

The + GATE connector provides a sweep gate signal that is generated by the time-base plug-in unit. The gate selector switch provides one of three possible gates (MAIN, AUXILIARY, and DELAY). The duration of the gate pulse is determined by the respective sweep. Auxiliary and Delay gates can only be produced by dual sweep time-base plug-in units. The amplitude of the gate signal is about 50 millivolts into 50 ohms or 10 volts into 1 megohm.

+ SAWTOOTH

The SAWTOOTH connector provides a positive going sample of the sawtooth from the time-base unit in the horizontal compartment. The rate of rise of the sawtooth signal is about 50 millivolts/unit of time into 50 ohms or 1 volt/unit of time into 1 megohm. Unit of time is determined by the time/division switch of the horizontal plug-in unit.

APPLICATIONS

The 7633 Oscilloscope and its associated plug-in units provide a very flexible measurement system. The capabilities of the overall system depend mainly upon the plug-in units that are chosen for use with this instrument. Specific applications for the individual plug-in units are described in the plug-in manuals. The overall system can also be used for many applications which are not described in detail either in this manual or in the manuals for the individual plug-in units. Contact your local Tektronix Field Office or representative for assistance in making specific measurements with this instrument.

The following books describe oscilloscope measurement techniques which can be adapted for use with this instrument.

John D. Lenk, 'Handbook of Oscilloscopes, Theory, and Application', Prentice-Hall Inc., Englewood Cliffs, New Jersey, 1968.

J. Czech, 'Oscilloscope Measuring Techniques', Springer-Verlag, New York, 1965.

J. F. Golding, 'Measuring Oscilloscopes', Transatlantic Arts, Inc., 1971.

Charles H. Roth Jr., 'Use of the Oscilloscope', A Programmed Text, Prentice-Hall Inc., Englewood Cliffs, New Jersey, 1970.

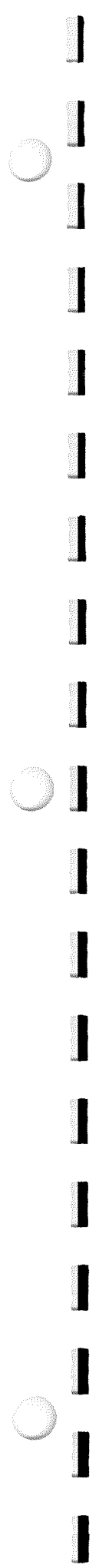

SPECIFICATIONS

INTRODUCTION

The Tektronix 7633 Storage Oscilloscope is a solid-state, high-performance instrument designed for fast writing rate storage applications. This instrument accepts Tektronix 7-series plug-in units to form a complete measurement system. The flexibility of this plug-in feature and the variety of plug-in units available allow the system to be used for many measurement applications.

This instrument will meet the electrical characteristics listed in the Performance Requirement column of Table 2-1 following complete calibration as given in the Service manual. The following characteristics apply over an ambient temperature range of 0°C to +50°C, except as otherwise indicated. Warmup time for given accuracy is 30 minutes.

NOTE

Many of the measurement capabilities of this instrument are determined by the choice of plug-in units. The following characteristics apply to the 7633 Storage Oscilloscope only. See the System Specifications later in this section for characteristics of the complete system.

TABLE 2-1
ELECTRICAL

Characteristic	Performance Requirement	Supplemental Information
VERTICAL DEFLECTION SYSTEM		
Deflection Factor	Compatible with all 7000-series plug-in units.	
Between Compartments	Within 1%.	
Low Frequency Linearity	0.1 division or less compression or expansion of a 2-division (at center-screen) signal when positioned vertically within the graticule area.	
Bandwidth	See System Specifications for 7600-series instruments.	
Step Response Risetime	See System Specifications for 7600-series instruments.	
Isolation Between Vertical Compartments	At least 100:1 from DC to 100 MHz.	

TABLE 2-1 (cont.)
ELECTRICAL

Characteristic	Performance Requirement	Supplemental Information
Delay Line		Permits viewing leading edge of trigger signal.
Chopped Mode		
Repetition Rate	1 MHz within 20%.	
Time Segment From Each Compartment	0.4 to 0.6 μ s.	
Difference in Delay Between Vertical Compartments		0.5 ns or less.
Vertical Display Modes	LEFT: Left vertical unit only. ALT: Dual trace, alternate between vertical units. ADD: Added algebraically. CHOP: Dual trace, chopped between vertical units. RIGHT: Right vertical unit only.	Selected by VERT MODE switch.

TRIGGERING

Trigger Source	LEFT VERT: From left vertical only.	Selected by TRIGGER SOURCE switch.
	VERT MODE: Determined by vertical mode switch.	
	RIGHT VERT: From right vertical only.	

HORIZONTAL DEFLECTION SYSTEM

Fastest Calibrated Sweep Rate	5 ns/division.	
Deflection Factor	Compatible with all 7000-series plug-in units.	

TABLE 2-1 (cont.)
ELECTRICAL

Characteristic	Performance Requirement	Supplemental Information
Low Frequency Linearity	0.1 division or less compression or expansion of a 2-division (at center-screen) signal when positioned horizontally within the graticule area.	
Phase Shift Between The Vertical and Horizontal Amplifiers	Less than 2° from dc to 35 kHz.	
Frequency Response Bandwidth (8-Division Reference)	At least 2 MHz.	

CALIBRATOR

Wave shape	Positive-going square wave or dc (dc voltage selected by internal jumper).	
Voltage Outputs	40 mV, 0.4 V, and 4 V.	Into 1 MΩ load.
Voltage Output Accuracy +15°C to +35°C	Within 1%.	
0°C to +50°C	Within 2%.	
Current Output	40 mA.	
Current Output Accuracy +15°C to +35°C	Within 2%.	Within optional current loop accessory (012-0259-00) connected between 4 V pin jack and ground pin jack.
0°C to +50°C	Within 3%.	
Repetition Rate		Approximately 1 kHz.
Output Resistance 50 mV and 0.4 V		Approximately 50Ω.
4 V		Approximately 450Ω.

TABLE 2-1 (cont.)
ELECTRICAL

Characteristic	Performance Requirement	Supplemental Information
OUTPUTS		
Camera Power (P1041 at crt bezel)		
Pin 1 — +15 V		
Pin 3 — single sweep reset		
Pin 5 — ground		
EXTERNAL Z AXIS INPUT		
Sensitivity (Full Intensity Range)	2 V peak to peak.	
Useful Input Voltage Versus Frequency	2 V peak to peak, dc to 2 MHz; reducing to 0.4 V peak to peak at 10 MHz.	
Polarity of Operation	Positive-going signal decreases intensity.	
Maximum Input Voltage		10 V (dc to peak ac).
Input Resistance		Approximately 500 Ω .
CHARACTER GENERATOR		
Character Size	Adjustable (Vertically Only).	
Modes of Operation	Free-run independent of sweep.	Selected by internal Readout mode switch.
	Triggered after sweep.	
POWER SOURCE		
Line Voltage Ranges 110 V nominal	100 V \pm 10%.	
	110 V \pm 10%.	
	120 V \pm 10%.	

TABLE 2-1 (cont.)
ELECTRICAL

Characteristic	Performance Requirement	Supplemental Information
Line Voltage Ranges		
220 V nominal	200 V \pm 10%.	
	220 V \pm 10%.	
	240 V \pm 10%.	
Line Frequency		50 to 60 Hz.
Maximum Power Consumption (115 Vac ; 60 Hz)		7633: 170 W, 1.9 A. R7633: 180 W, 2 A.
Fuse Data		
110 V line (F1000)		3.2 A slow blow.
220 V line (F1000)		1.6 A slow blow.
+130 V Supply (F855)		0.15 A fast blow.
+15 V unregulated		2.0 A fast blow.

DISPLAY (CRT)

Cathode-Ray Tube Type	T7411.	
Graticule		
Type	Internal and illuminated.	
Area	8 x 10 divisions	
Reduced Scan	8 x 10 divisions in center of faceplate	
Division	0.9 centimeter Full Scan 0.45 centimeter Reduced Scan	
Phosphor	P31	
Accelerating Potential	Approximately 8.5 kV (approximately 10 kV in Reduced Scan).	
BEAMFINDER	Limits display to within graticule area when BEAMFINDER switch is actuated.	

TABLE 2-1 (cont.)
ELECTRICAL

Characteristic	Performance Requirement	Supplemental Information
Stored Writing Speed		
Full Scan (center 6 x 8 divisions)		
FAST VAR PERSIST	150 div/ μ s	
FAST BISTABLE	50 div/ μ s	
VAR PERSIST	0.5 div/ μ s	
BISTABLE	0.03 div/ μ s	
Reduced Scan		
FAST VAR PERSIST	2222 div/ μ s	
FAST BISTABLE	400 div/ μ s	
VAR PERSIST	3 div/ μ s	
BISTABLE	0.2 div/ μ s	

SIGNALS OUT

VERT SIG OUT	See Systems Specifications for 7600-series instruments.	
Vertical Signals	LEFT, RIGHT, ALT and ADD	Selected by TRIG SOURCE switch.
Gain		
Into 50 Ω		25 mV/division \pm 20% system crt to VERT SIG OUT.
Into 1 M Ω		0.5 V/division \pm 20% system crt to VERT SIG OUT.
Risetime (Into 50 Ω)		5 ns or less.
Centering		\pm 3 division system crt to VERT SIG OUT. (1.5 V into 1 M Ω or 75 mV into 50 Ω .)
Output Resistance		950 Ω within 2%.

TABLE 2-1 (cont.)
ELECTRICAL

Characteristic	Performance Requirement	Supplemental Information
+GATE OUT		
Gate Signals	MAIN, AUXILIARY, and DELAY.	Selected by Gate Selector switch.
Output		
Into 50 Ω		0.5 V within 10%.
Into 1 M Ω		10 V within 10%.
Risetime (Into 50 Ω)		20 ns or less.
Output Resistance		950 Ω within 2%.
+SAWTOOTH OUT		
Output		
Into 50 Ω		50 mV/unit time ¹ within 15%.
Into 1 M Ω		1 V/unit time ¹ within 10%.
Output Resistance		950 Ω within 2%.

ELECTRO-MAGNETIC INTERFERENCE

Electro-magnetic interference(emi) in accordance with MIL-STD-461A as tested in MIL-STD-462 (when equipped with Option 3)	Any unused plug-in compartments must be covered with a blank plug-in panel (emi shielded) in order to meet emi specifications. See Options section for additional information.	
Radiated interference	Interference radiated from the instrument under test within the given limits from 150 kilohertz to 1000 megahertz.	
Conducted interference	Interference conducted out of the instrument under test through the power cord within the given limits from 150 kilohertz to 25 megahertz.	
Transportation (packaged instrument, without plug-ins)	Qualifies under National Safe Transit Committee test procedure 1A, Category II.	

¹ Referenced to Time/Div setting.

**TABLE 2-2
ENVIRONMENTAL**

Characteristic	Information
<i>NOTE</i>	
<i>This instrument will meet the electrical characteristics given in the Performance Requirement column of the Specifications over the following environmental limits.</i>	
Temperature Range	
Operating	0° C to +50° C.
Non-Operating	-55° C to +75° C.
Altitude	
Operating	15,000 ft.
Non-Operating	Test limit 50,000 ft.

Transportation (packaged instrument, without plug-in units) qualifies under National Safe Transit test procedure 1A, Category II.

**TABLE 2-3
PHYSICAL**

Characteristic	Information
Ventilation	Safe operating temperature maintained by forced cooling. Automatic resetting thermal cutout protects instrument from overheating.
Finish	Anodized aluminum front panel. Painted cabinet.
7633 Overall Dimensions (measured at maximum point)	
Height	12.0 in (30.4 cm).
Width	8.7 in (23.0 cm).
Length	23.7 in (50.2 cm).
Net Weight (instrument only)	30 lb (13.6 kg).

TABLE 2-3 (cont.)

PHYSICAL

Characteristic	Information
R7633 Overall Dimensions (measured at maximum points)	
Height	5.25 in (13.4 cm).
Width	19 in (48.3 cm).
Length	23 in (57.96 cm).
Net Weight (instrument only)	30 lb (13.6 kg).

STANDARD ACCESSORIES

Standard accessories supplied with the 7633 are given in the Mechanical Parts List, in the Service manual. For optional accessories available for use with this instrument, see the Tektronix, Inc., catalog.

TABLE 2-4
7633 SYSTEM SPECIFICATIONS

Amplifier Plug-In Unit	Probe	Bandwidth	Risetime (Calculated)	Accuracy *			SIG OUT	
				EXT CAL	INT CAL	BW	T _r	
				0.25% Acc	15 to 35° C			0 to 50° C
7A11	Integral	100 MHz	3.5 ns	2%	3%	4%	60 MHz	5.9 ns
7A12	None P6106	80 MHz	4.4 ns	2%	3%	4%	55 MHz	6.4 ns
		80 MHz	4.4 ns	3%	4%	5%	55 MHz	6.4 ns
7A13	None or P6106 or P6055	75 MHz	4.7 ns	1.5%	2.5%	3.5%	55 MHz	6.4 ns
		55 MHz	6.4 ns	1.5%	2.5%	3.5%	45 MHz	7.8 ns
7A14	P6021 P6022	50 MHz	7.0 ns	2%	3%	4%	40 MHz	8.8 ns
		80 MHz	4.7 ns	2%	3%	4%	50 MHz	7.0 ns
7A15A	None P6065A	65 MHz	5.4 ns	2%	4%	5%	50 MHz	7.0 ns
		60 MHz	5.4 ns	3%	4%	5%	50 MHz	7.0 ns
7A16A	None P6106	100 MHz	3.5 ns	2%	3%	4%	60 MHz	5.9 ns
		100 MHz	3.5 ns	3%	4%	5%	60 MHz	5.9 ns
7A17	None	100 MHz	3.5 ns				15 MHz	24 ns
7A18	None P6065A	75 MHz	4.7 ns	2%	3%	4%	50 MHz	7.0 ns
		70 MHz	4.7 ns	3%	4%	5%	50 MHz	7.0 ns
7A19	None P6056/ P6057	100 MHz	3.5 ns	3%	4%	5%	65 MHz	5.4 ns
		100 MHz	3.5 ns	4%	5%	6%	65 MHz	5.4 ns
7A22	None or P6055 or P6060	1.0 MHz, ±10%	350 ns, ±9%	2%	3%	4%	1.0 MHz, ±10%	350 ns ±9%
7A24	None P6056/ P6057	100 MHz	3.5 ns				60 MHz	5.9 ns
		100 MHz	3.5 ns				60 MHz	5.9 ns
7A26	None P6106	100 MHz	3.5 ns	2%	3%	4%	60 MHz	5.9 ns
		100 MHz	3.5 ns	3%	4%	5%	60 MHz	5.9 ns

*Deflection Factor Accuracy. Plug-in gain set at a temperature within 10° C of the operating temperature.

Bandwidth checked from 0° C to +50° C.

The bandwidth of a vertical plug-in used in the horizontal compartment is 2 MHz except for the 7A22 which has a bandwidth of 850 kHz. The X-Y phase shift between 2 similar units is 2° at 35 kHz.

RACKMOUNTING INSTRUCTIONS

INTRODUCTION

The R7633 is designed for installation in a standard 19-inch rack with Universal hole spacing. If a rack with other than Universal hole spacing is used, additional mounting holes may need to be drilled.

INSTALLATION INSTRUCTIONS

A drawing showing the major dimensions of the R7633 is shown in Figure 3-6.

RACK DIMENSIONS

HEIGHT

At least 5.25 inches of vertical space is required to mount this instrument in a rack. This gives enough clearance for adjacent instruments and panels. (Additional height may be required if an oscilloscope camera is to be used with this instrument.)

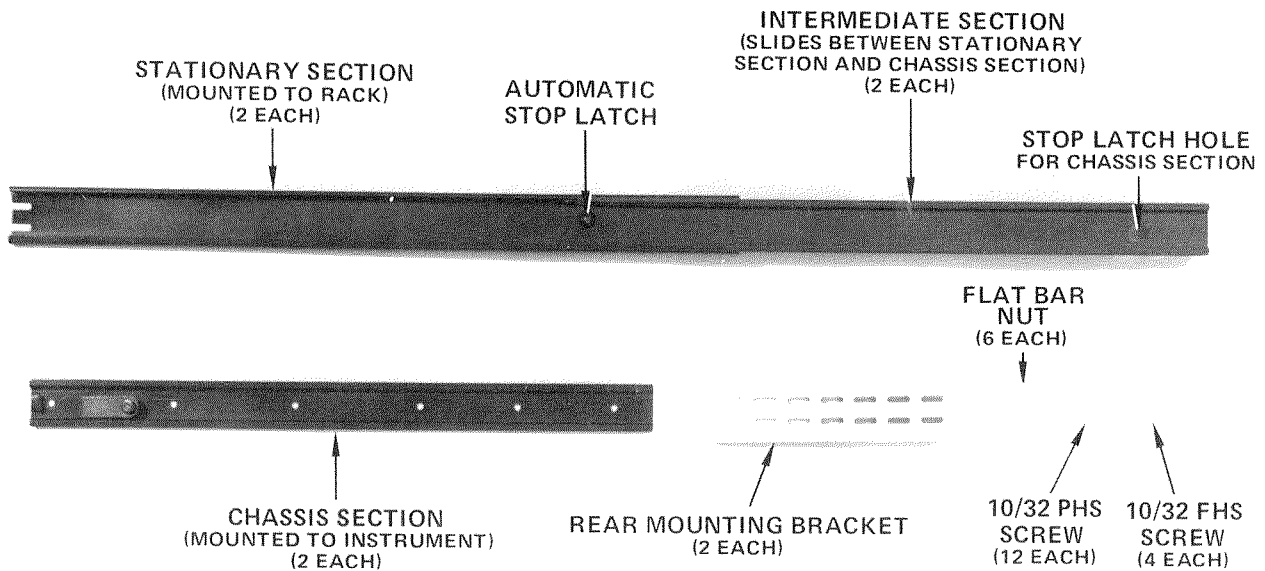

Figure 3-1. Slide out track assembly and mounting hardware.

Rackmounting Instructions—7633/R7633 Operators

WIDTH

Minimum space between the front rails of the rack is 17 - 5/8 inches. This space allows the slide-out tracks to operate freely, permitting the R7633 to move in and out of the rack.

DEPTH

Total depth required to mount this instrument in an enclosed-cabinet rack is 24 inches. This allows enough space for air circulation, signal connections, and the power cord.

The rear mounting brackets allow this instrument to be mounted in racks with 14-5/8 to 28-1/2 inches between the front and rear rails. The R7633 must be properly supported at the rear. Improper support may result in instrument damage.

SLIDE-OUT TRACKS

The slide-out tracks provided with this instrument permit it to be extended out of the rack for maintenance and calibration without removing it from the rack. Be sure the power cord and signal cables are long enough to allow operation in the extended position.

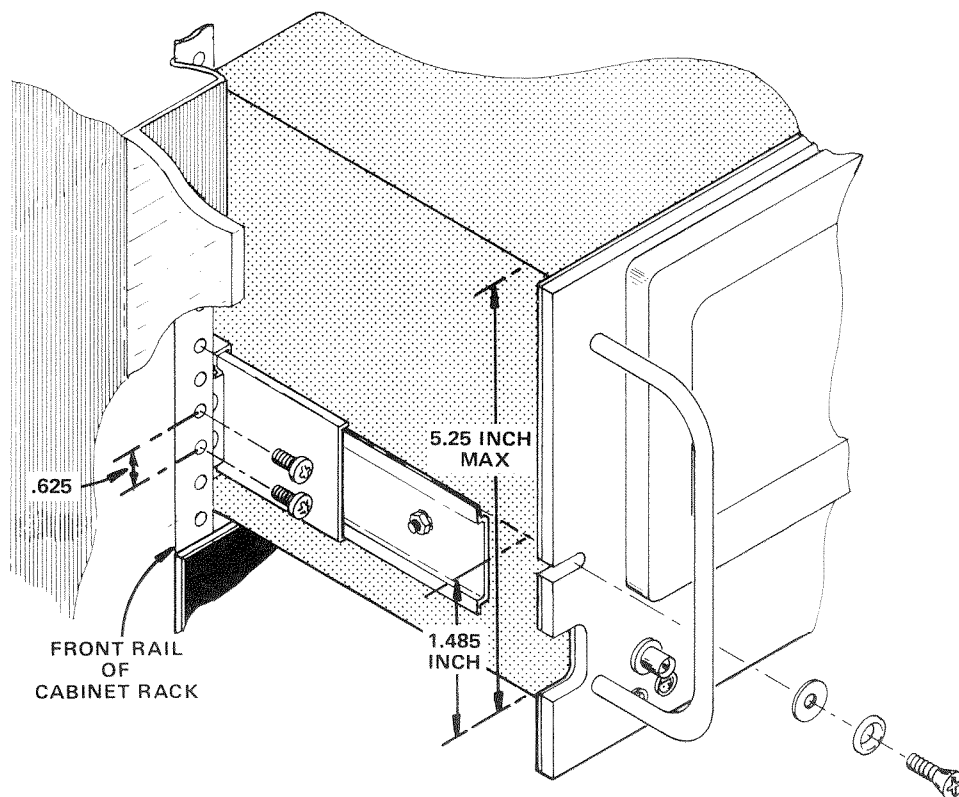

Figure 3-2. Vertical mounting position of the left stationary section and the securing hole location. These dimensions also apply to the right front rail.

Rackmounting Instructions—7633/R7633 Operators

The slide-out tracks consist of two assemblies, one for the left side of the instrument and one for the right side. Figure 3-1 shows the slide-out track assembly. The stationary section of each assembly attaches to the front and rear rails of the rack. The chassis sections allow the instrument to be extended out of the rack.

The hardware needed to mount the tracks to the rack is also shown in Figure 3-1. Since enough hardware is supplied to make the tracks compatible with a variety of racks and installation methods, some of it may not be needed.

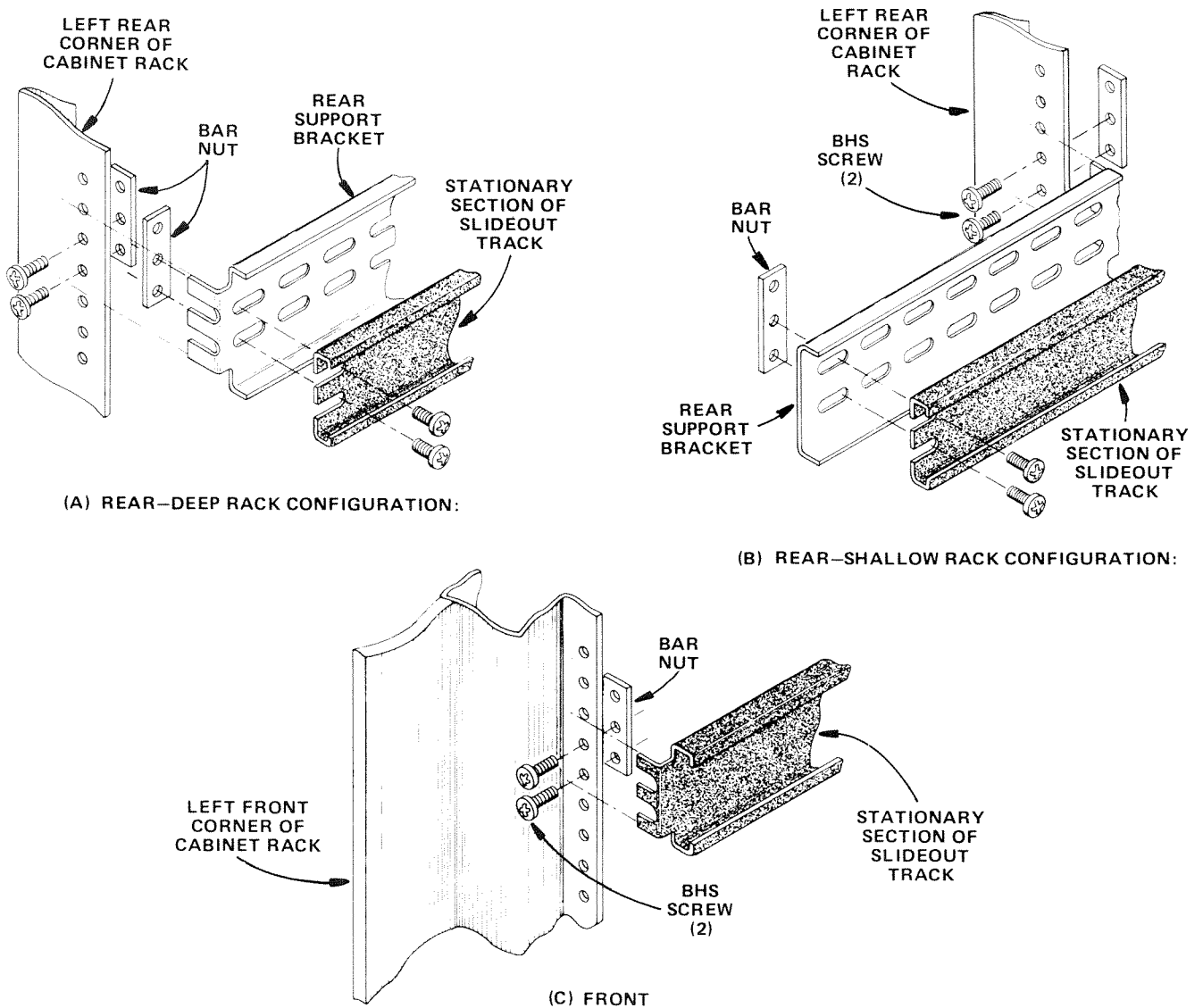

Figure 3-3. Details for mounting stationary sections.

MOUNTING PROCEDURE

1. Select the proper front-rail mounting holes for the stationary sections using the measurements shown in Figure 3-2.
2. Mount the front flanges of the stationary sections to the front rails of the rack with a bar nut and two pan-head screws (see Figure 3-3).

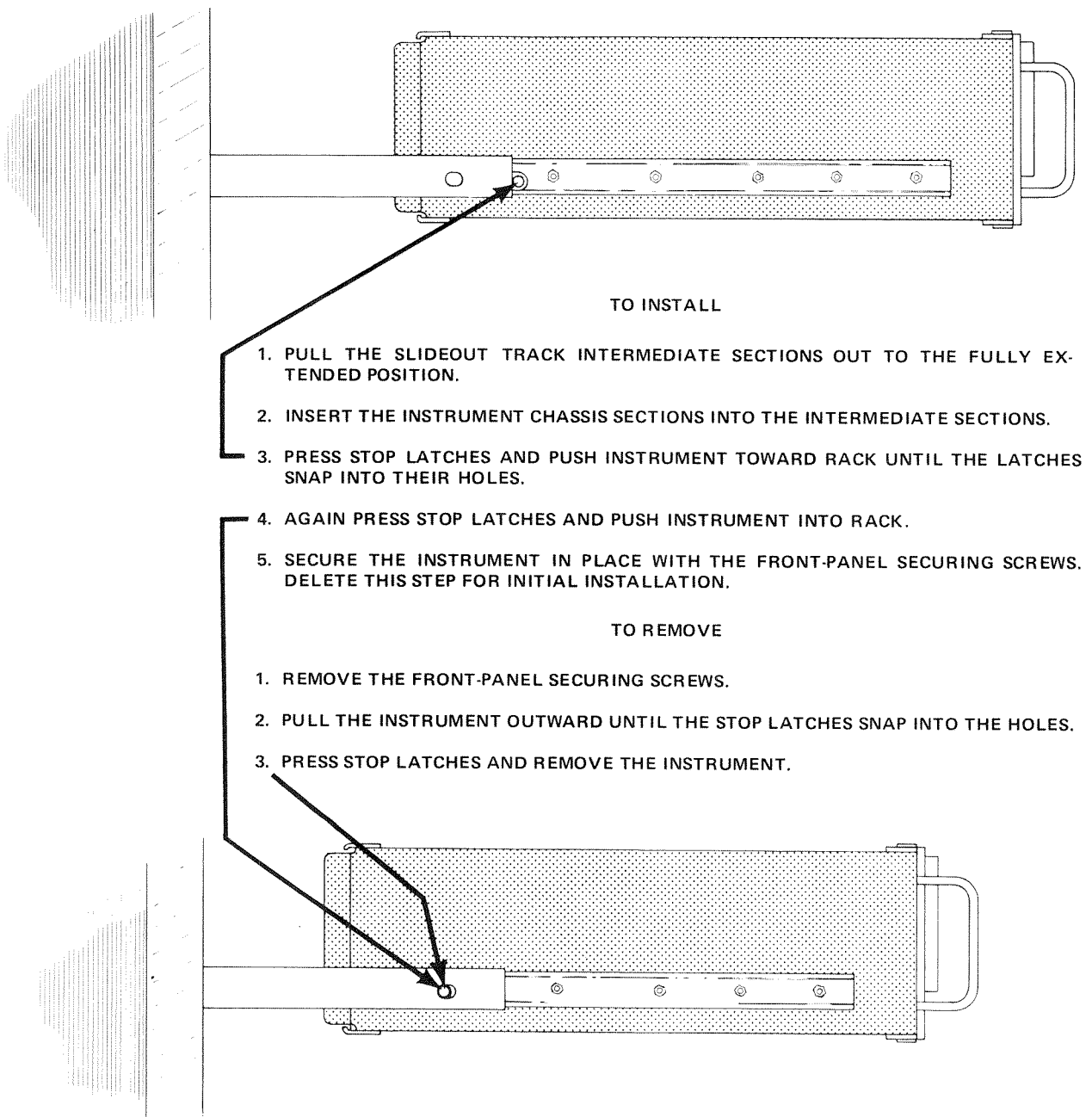

Figure 3-4. Installing and removing the instrument.

Rackmounting Instructions—7633/R7633 Operators

3. Mount the rear of the stationary sections to the rear rails using the method shown in Figure 3-3. Be sure that the tracks are level.

NOTE

If the rails of the rack are tapped, either drill out the holes with a 0.196-inch drill, or mount the front flanges in front of the rails.

4. Refer to Figure 3-4 to install the instrument into the rack.
5. See Figure 3-5 to adjust the alignment of the stationary sections.
6. After the tracks operate smoothly, connect the power cord and all necessary cables to the rear panel connectors. Push the instrument all the way into the rack and secure it to the front rail of the rack with the securing screws and washers shown in Figure 3-2. If the securing holes are not tapped, use a 'speed-nut' or similar item to install the securing screws.

REMOVING OR INSTALLING THE INSTRUMENT

After initial installation and adjustment of the slide-out tracks, the instrument can be removed or installed by following the instructions given in Figure 3-4. No further adjustments are required under normal conditions.

SLIDE-OUT TRACK LUBRICATION

The special finish on the sliding surfaces of the tracks provides permanent lubrication. However, if the tracks require additional lubrication, a thin coat of paraffin can be rubbed onto the sliding surfaces.

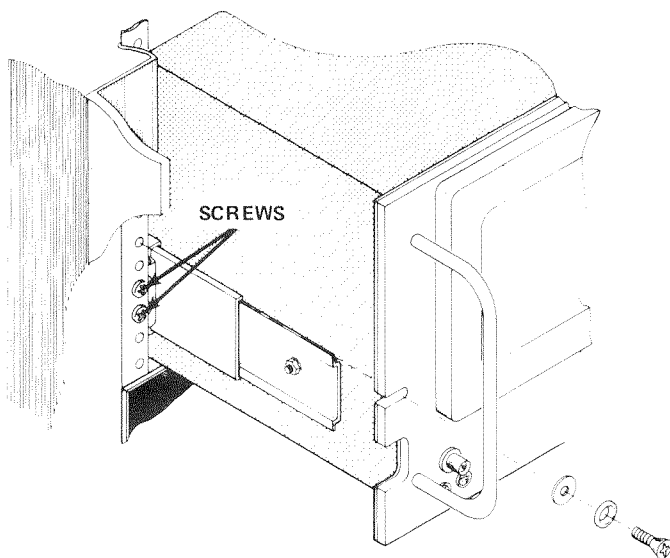

1. LOOSEN SCREWS ON BOTH SIDES (LEFT SIDE SHOWN).
2. ALLOW SLIDES TO SEEK PROPER WIDTH.
3. CENTER INSTRUMENT.
4. RETIGHTEN SCREWS.
5. PUSH THE INSTRUMENT ALL THE WAY INTO THE RACK. IF TRACKS DO NOT SLIDE SMOOTHLY, CHECK FOR CORRECT SPACING BETWEEN THE REAR SUPPORTS.

Figure 3-5. Adjusting the slide out tracks for smooth sliding action.

Rackmounting Instructions—7633/R7633 Operators

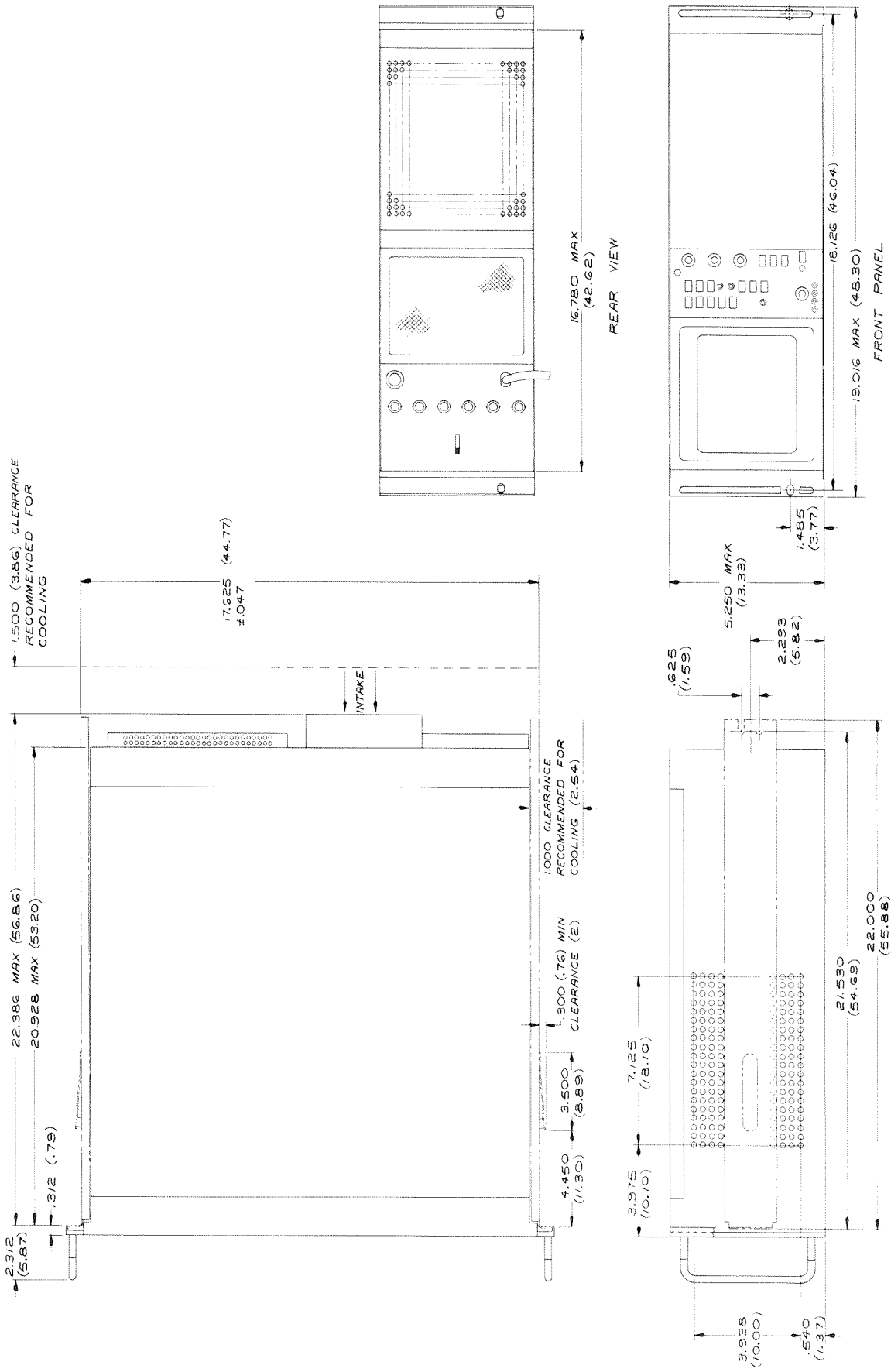

NOTES:
 1. DIMENSIONS IN PARENTHESIS ARE
 IN CENTIMETERS
 2. SCALE: NONE

Figure 3-6. Dimensional drawing.

OPTIONS

The 7633/R7633 Storage Oscilloscope is available with the following options:

OPTION 1

This option deletes the Readout System. Operation of the instrument is unchanged except there is no alpha-numeric display on the crt.

OPTION 3

This option provides electro-magnetic interference (emi) shielding so the instrument will meet the emi specification given in Section 2.

OPTION 5

This option provides a special fan to allow operation from 50 Hertz to 400 Hertz line frequency.

OPTION 7

This option deletes all rear panel connectors except the Z-AXIS input.

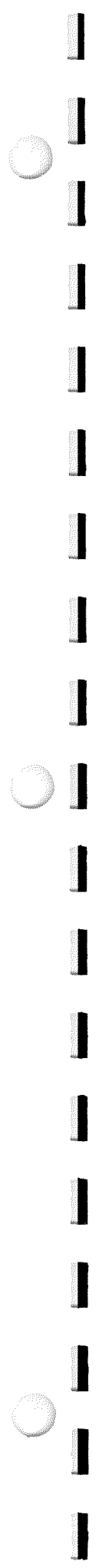

MANUAL CHANGE INFORMATION

At Tektronix, we continually strive to keep up with latest electronic developments by adding circuit and component improvements to our instruments as soon as they are developed and tested.

Sometimes, due to printing and shipping requirements, we can't get these changes immediately into printed manuals. Hence, your manual may contain new change information on following pages.

A single change may affect several sections. Since the change information sheets are carried in the manual until all changes are permanently entered, some duplication may occur. If no such change pages appear following this page, your manual is correct as printed.

SERVICE NOTE

Because of the universal parts procurement problem, some electrical parts in your instrument may be different from those described in the Replaceable Electrical Parts List. The parts used will in no way alter or compromise the performance or reliability of this instrument. They are installed when necessary to ensure prompt delivery to the customer. Order replacement parts from the Replaceable Electrical Parts List.

CALIBRATION TEST EQUIPMENT REPLACEMENT

Calibration Test Equipment Chart

This chart compares TM 500 product performance to that of older Tektronix equipment. Only those characteristics where significant specification differences occur, are listed. In some cases the new instrument may not be a total functional replacement. Additional support instrumentation may be needed or a change in calibration procedure may be necessary.

Comparison of Main Characteristics

DM 501 replaces 7D13		
PG 501 replaces 107 108	PG 501 - Risetime less than 3.5 ns into 50 Ω . PG 501 - 5 V output pulse; 3.5 ns Risetime	107 - Risetime less than 3.0 ns into 50 Ω . 108 - 10 V output pulse 1 ns Risetime
PG 502 replaces 107 108 111	PG 502 - 5 V output PG 502 - Risetime less than 1 ns; 10 ns Pretrigger pulse delay	108 - 10 V output 111 - Risetime 0.5 ns; 30 to 250 ns Pretrigger pulse delay
PG 508 replaces 114 115 2101	Performance of replacement equipment is the same or better than equipment being replaced.	
PG 506 replaces 106 067-0502-01	PG 506 - Positive-going trigger output signal at least 1 V; High Amplitude output, 60 V. PG 506 - Does not have chopped feature.	106 - Positive and Negative-going trigger output signal, 50 ns and 1 V; High Amplitude output, 100 V. 0502-01 - Comparator output can be alternately chopped to a reference voltage.
SG 503 replaces 190, 190A, 190B 191 067-0532-01	SG 503 - Amplitude range 5 mV to 5.5 V p-p. SG 503 - Frequency range 250 kHz to 250 MHz.	190B - Amplitude range 40 mV to 10 V p-p. 0532-01 - Frequency range 65 MHz to 500 MHz.
SG 504 replaces 067-0532-01 067-0650-00	SG 504 - Frequency range 245 MHz to 1050 MHz.	0532-01 - Frequency range 65 MHz to 500 MHz.
TG 501 replaces 180, 180A 181 184 2901	TG 501 - Trigger output-slaved to marker output from 5 sec through 100 ns. One time-mark can be generated at a time. TG 501 - Trigger output-slaved to market output from 5 sec through 100 ns. One time-mark can be generated at a time. TG 501 - Trigger output-slaved to marker output from 5 sec through 100 ns. One time-mark can be generated at a time.	180A - Trigger pulses 1, 10, 100 Hz; 1, 10, and 100 kHz. Multiple time-marks can be generated simultaneously. 181 - Multiple time-marks 184 - Separate trigger pulses of 1 and 0.1 sec; 10, 1, and 0.1 ms; 10 and 1 μ s. 2901 - Separate trigger pulses, from 5 sec to 0.1 μ s. Multiple time-marks can be generated simultaneously.

NOTE: All TM 500 generator outputs are short-proof. All TM 500 plug-in instruments require TM 500-Series Power Module.